

Neutron Time-of-Flight Measurements Initiated with 25-keV Deuterons

Ethan Nagasing, Corey Wilkinson, Ethan Smith, Kallah Eddy, Kurt Fletcher, Stephen Padalino

State University of New York at Geneseo

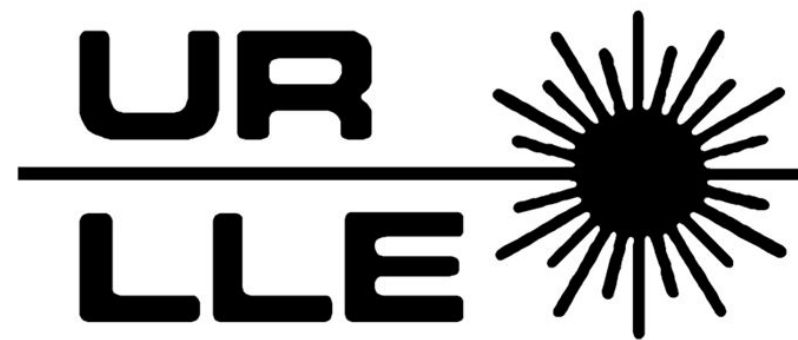

Abstract

Neutron time-of-flight (nTOF) measurements have been completed using d-d fusion reactions produced by 25 keV deuterons. Deuterons produced using the SUNY Geneseo 30 kV Peabody Scientific Duoplasmatron Ion Source are focused onto thick deuterated polyethylene films producing fusion products. In the laboratory coordinate system, 2.595 MeV neutrons detected by a BC-412 plastic scintillator at 39° correspond to 0.699 MeV ^3He ions detected by a surface barrier detector (SBD) placed at 135°. At these low energies, the charged particle spectra have little to no background. Timing signals from the SBD preamplifier initiate a start signal and the associated timing signal from the photomultiplier tube initiates the stop signal. By placing the scintillator at various distances from the target, the time-of-flight spectra can be used to determine an experimental value for the neutron energy, and this provides confirmation of the method. Using this nTOF technique, the neutron response for different scintillation detectors can be determined.

Motivation

Scintillators are often used for neutron diagnostics in Inertial Confinement Fusion (ICF) experiments. The light decay curve is unique to the scintillation material and varies with excitation source. The associated particle technique can be used to distinguish the light decay curve of a neutron scintillation event from other events, allowing for distinction between reaction neutrons and other radiation sources such as gamma rays, background neutrons and muons.

Low Energy Ion Facility (LEIF)

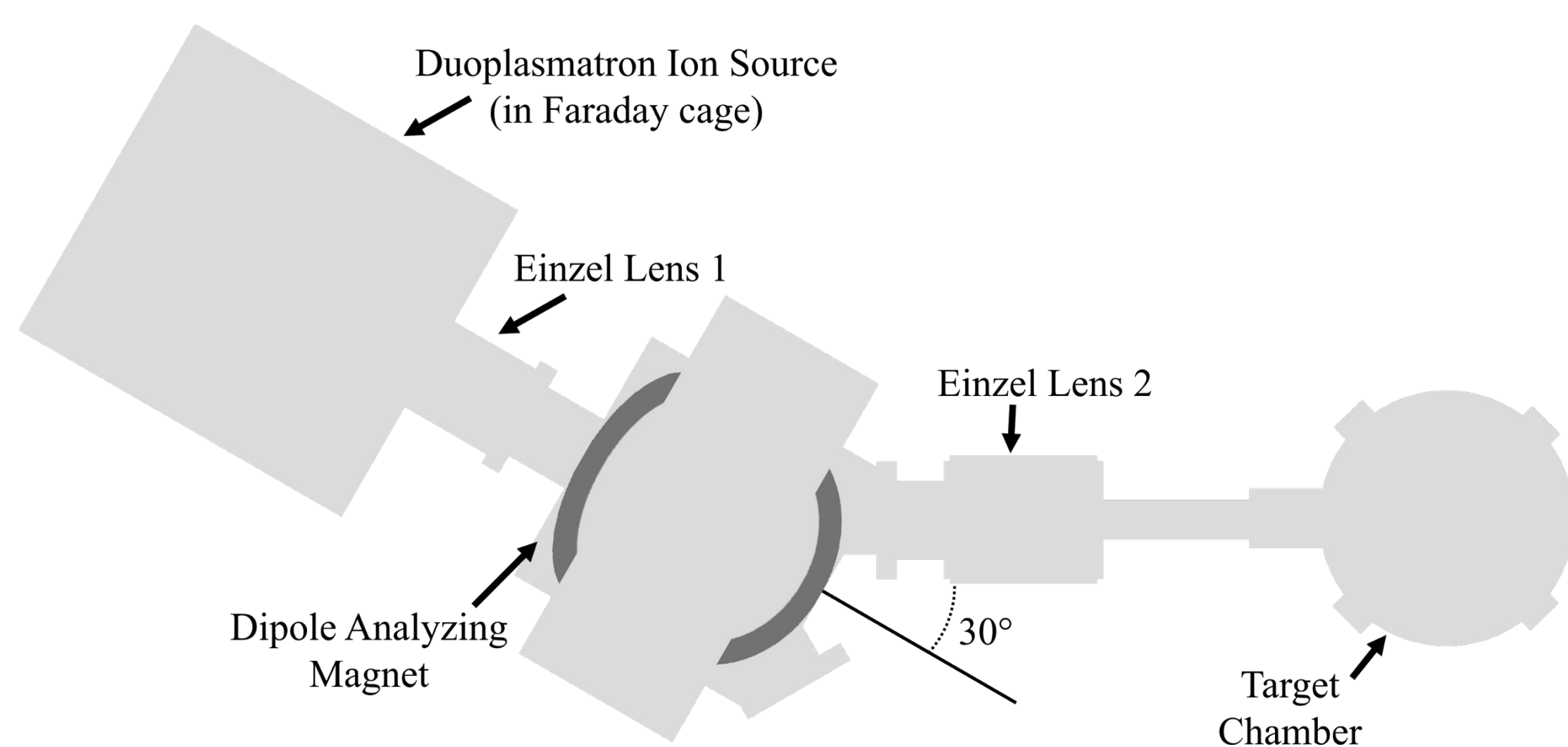

Experimental Setup

25 keV deuterons incident on a deuterated polyethylene target generate d-d fusion reactions. Two-body kinematics calculations indicate that 2.595 MeV neutrons are emitted at a 39° angle to the right of the incident beam while the associated 0.699 MeV ^3He ions emerge at 135° to the left.

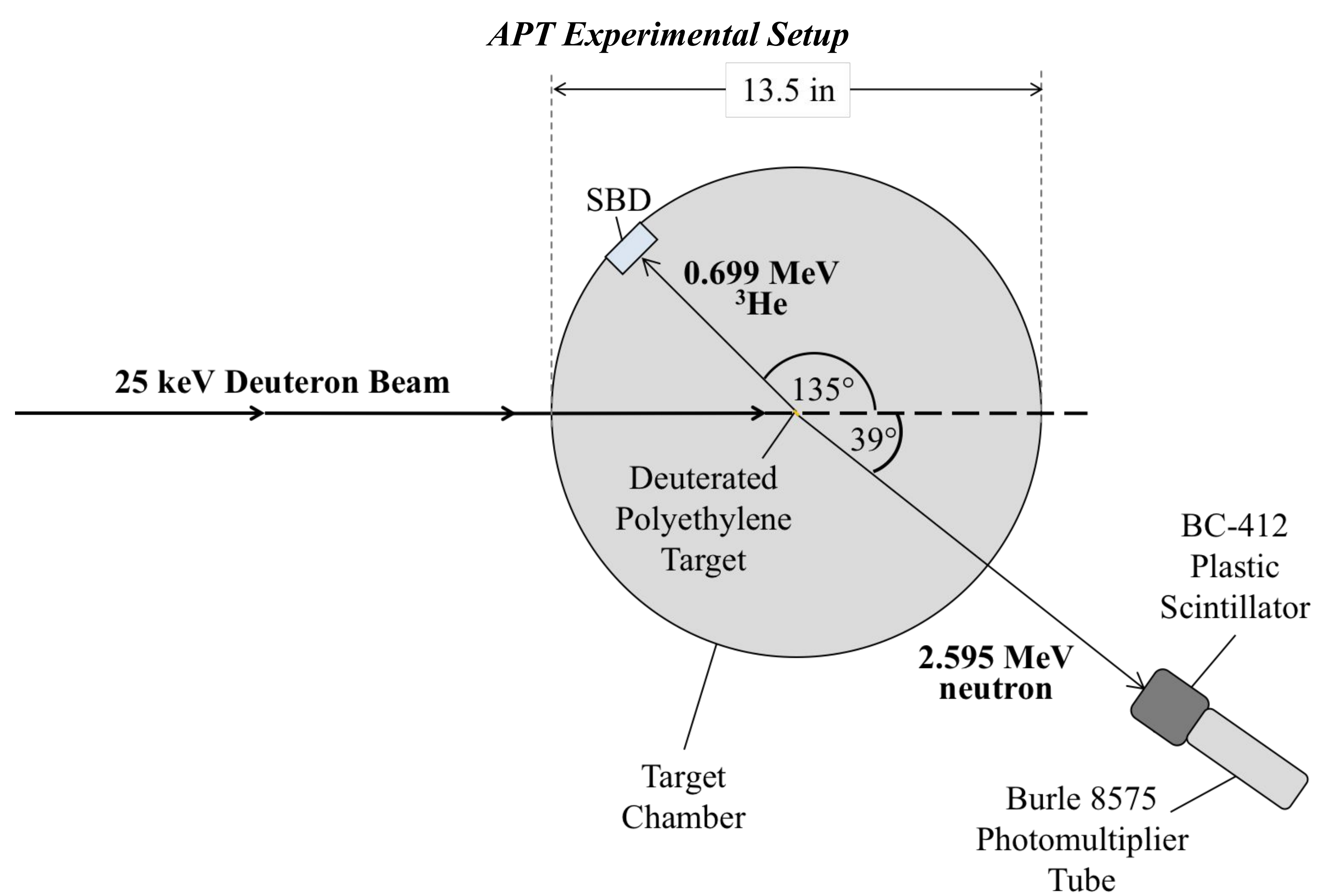
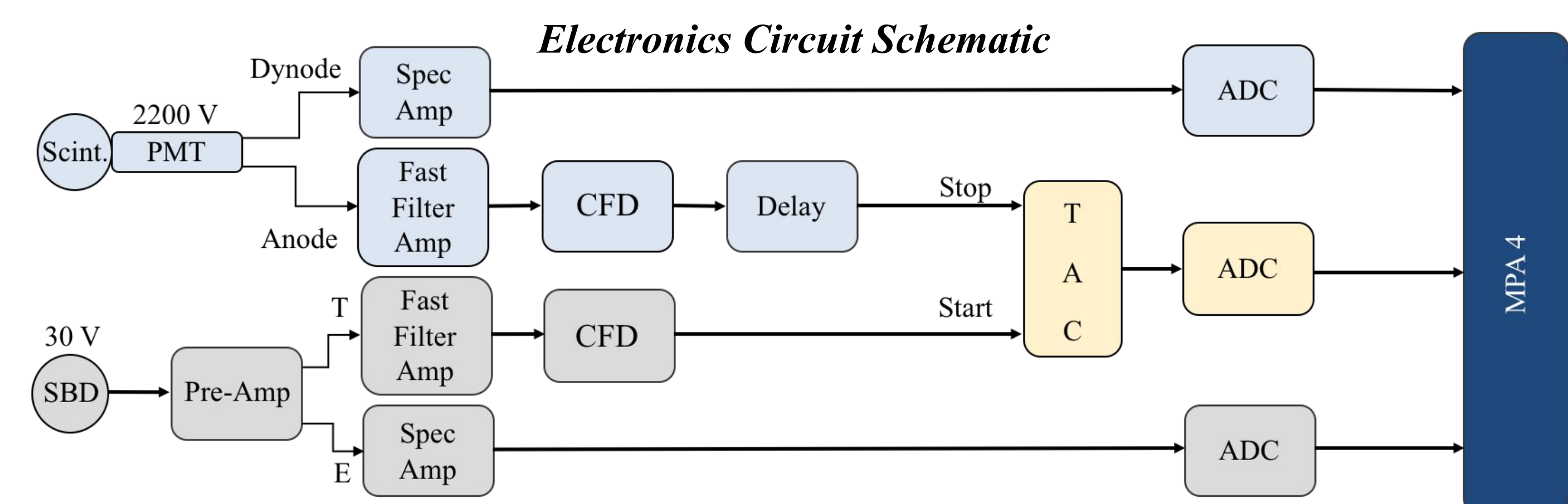
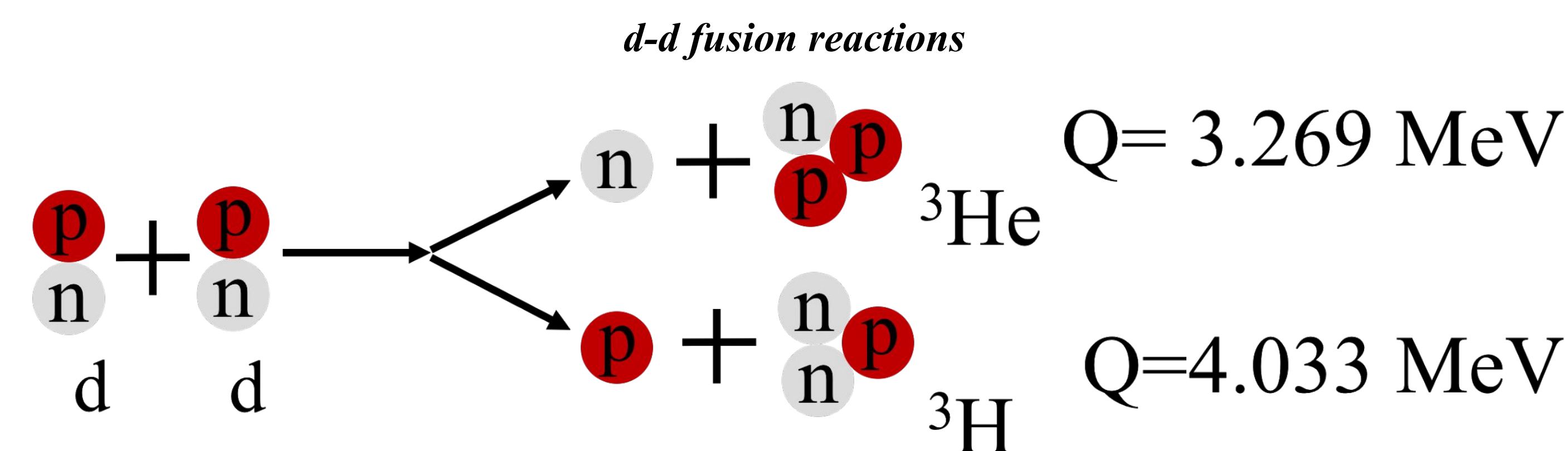

Procedure

To confirm that the Associated Particle Technique (APT) is selecting only d-d fusion neutrons, the scintillator was placed at five different distances from the target and the time of flight was determined. Using these data, the kinetic energy of the neutron is compared to the expected value.

Results

Energy spectra for fusion products produced by the LEIF were collected with minimal noise and a peak resolution of about 200 keV. A typical spectrum for the scintillator is shown below on the left and to its right is a projection of the scintillator spectrum in coincidence with the SBD, showing the response of the scintillator to neutrons only.

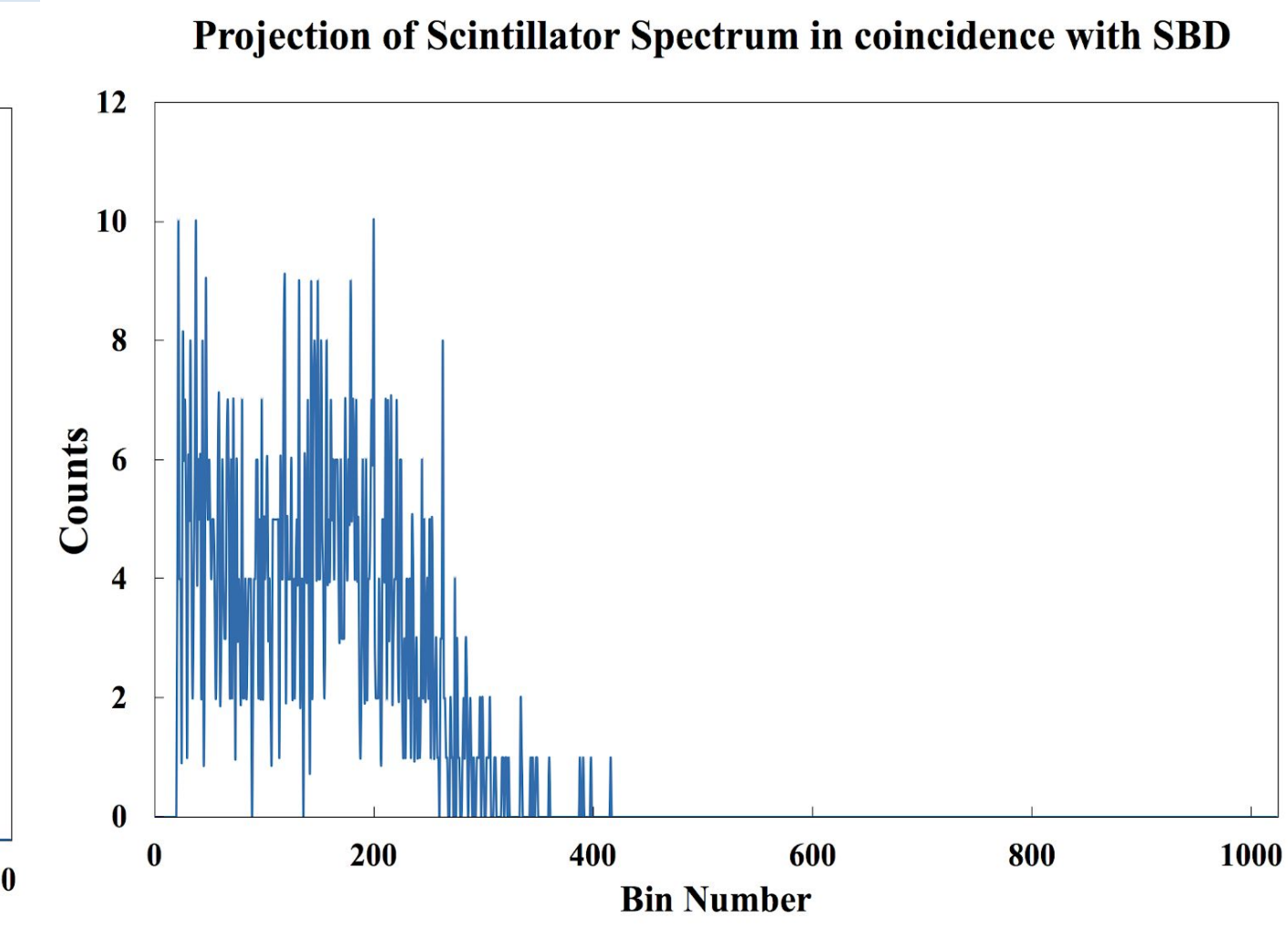
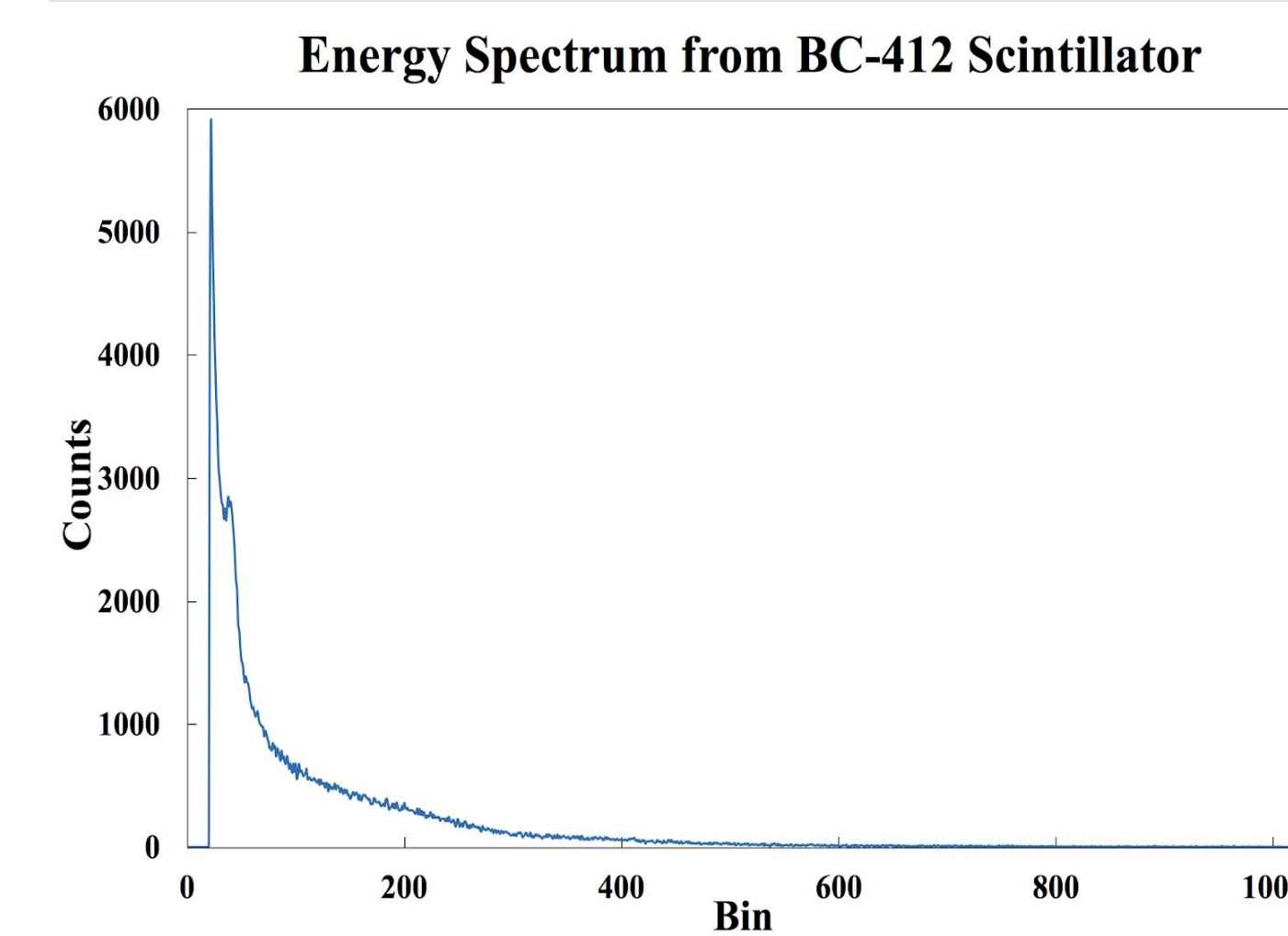
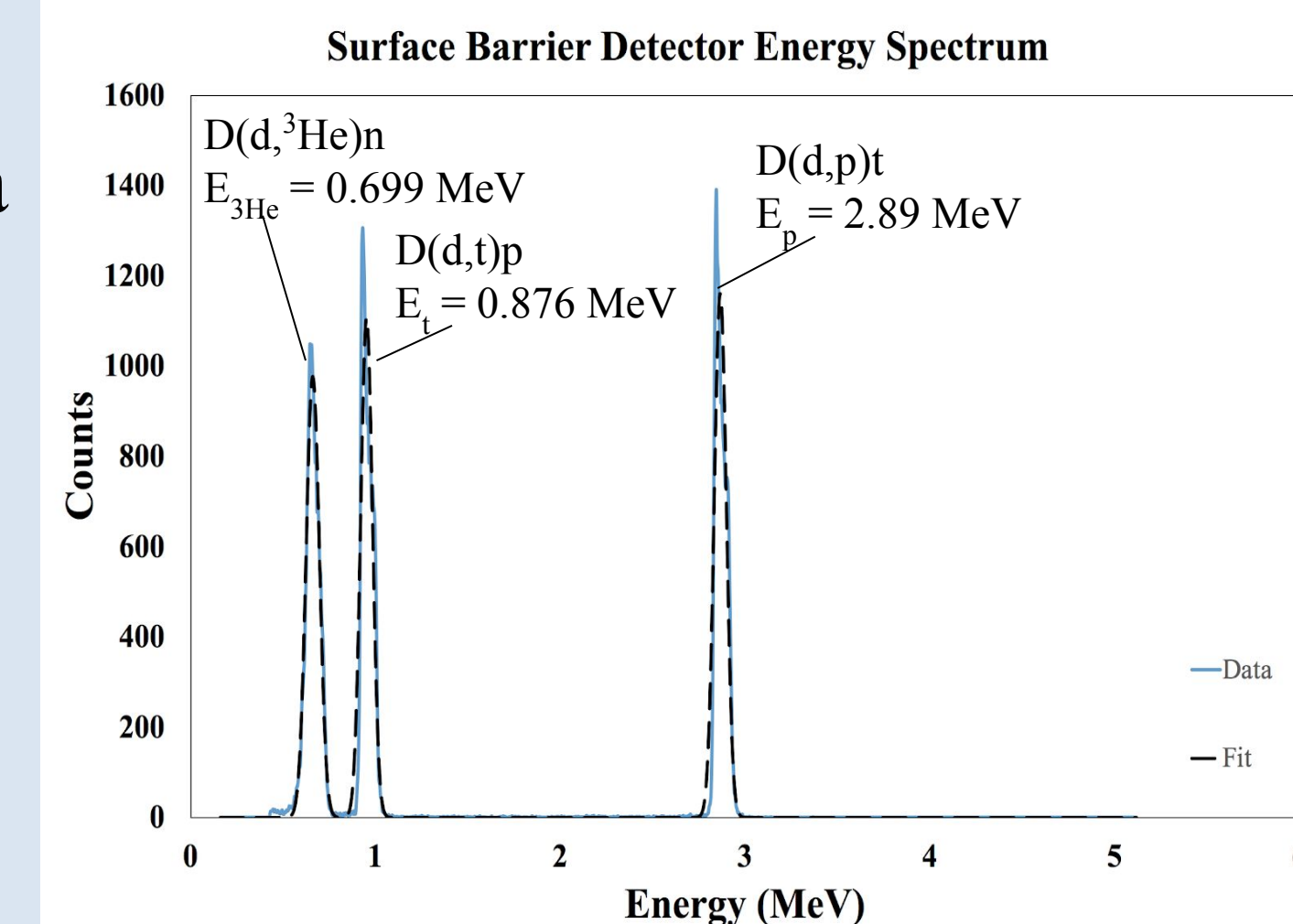

The neutron time of flight was determined by examining shifts in the TAC spectra as the scintillator was moved different known distances from the target chamber. The neutron velocity was found to be $(2.099 \pm 0.014) \times 10^7$ m/s. After calculating the neutron velocity, the neutron energy was determined to be 2.30 ± 0.31 MeV, which is consistent with the predicted neutron energy, 2.595 MeV. This confirms the APT is selecting only d-d fusion neutrons.

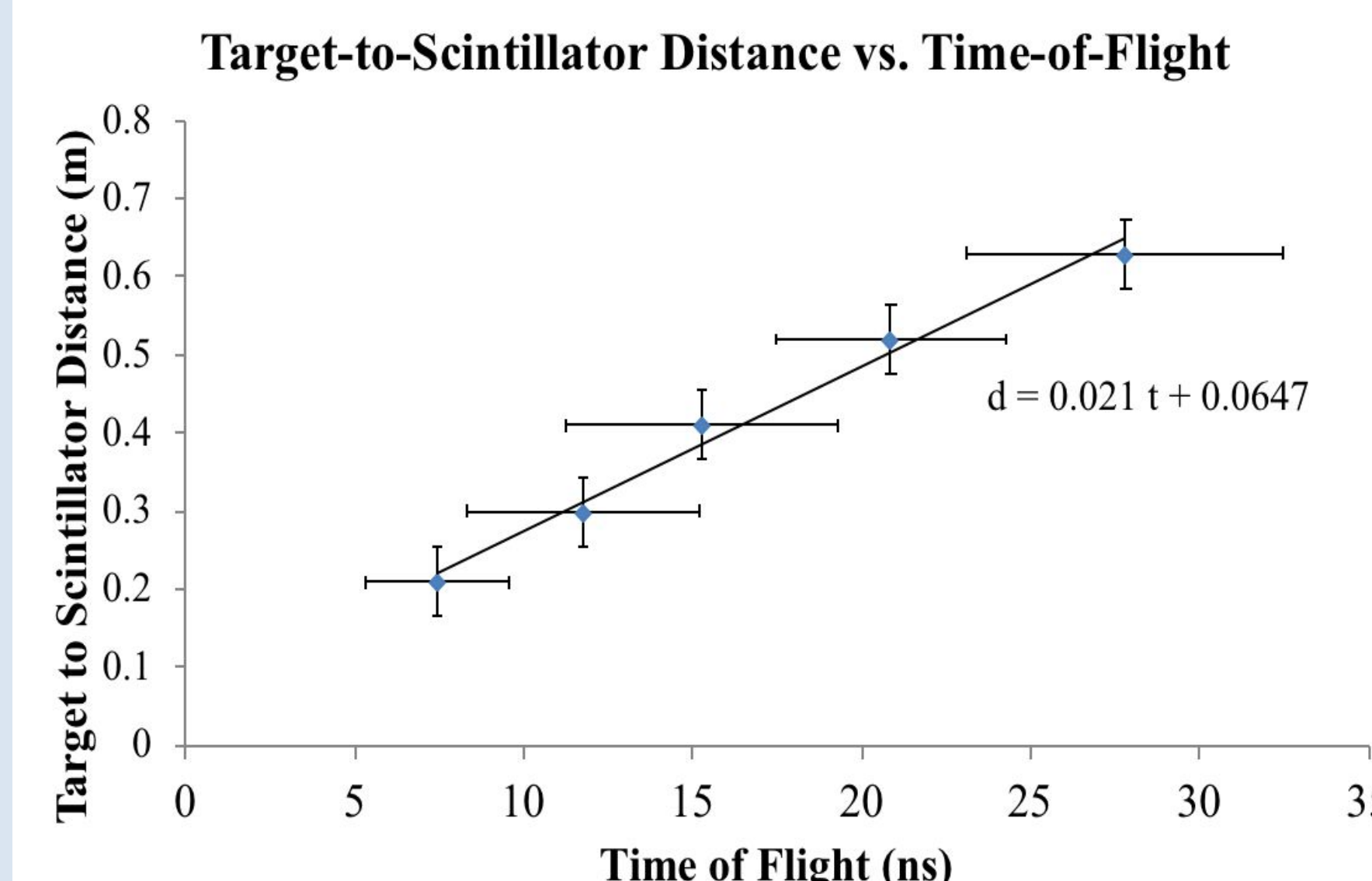
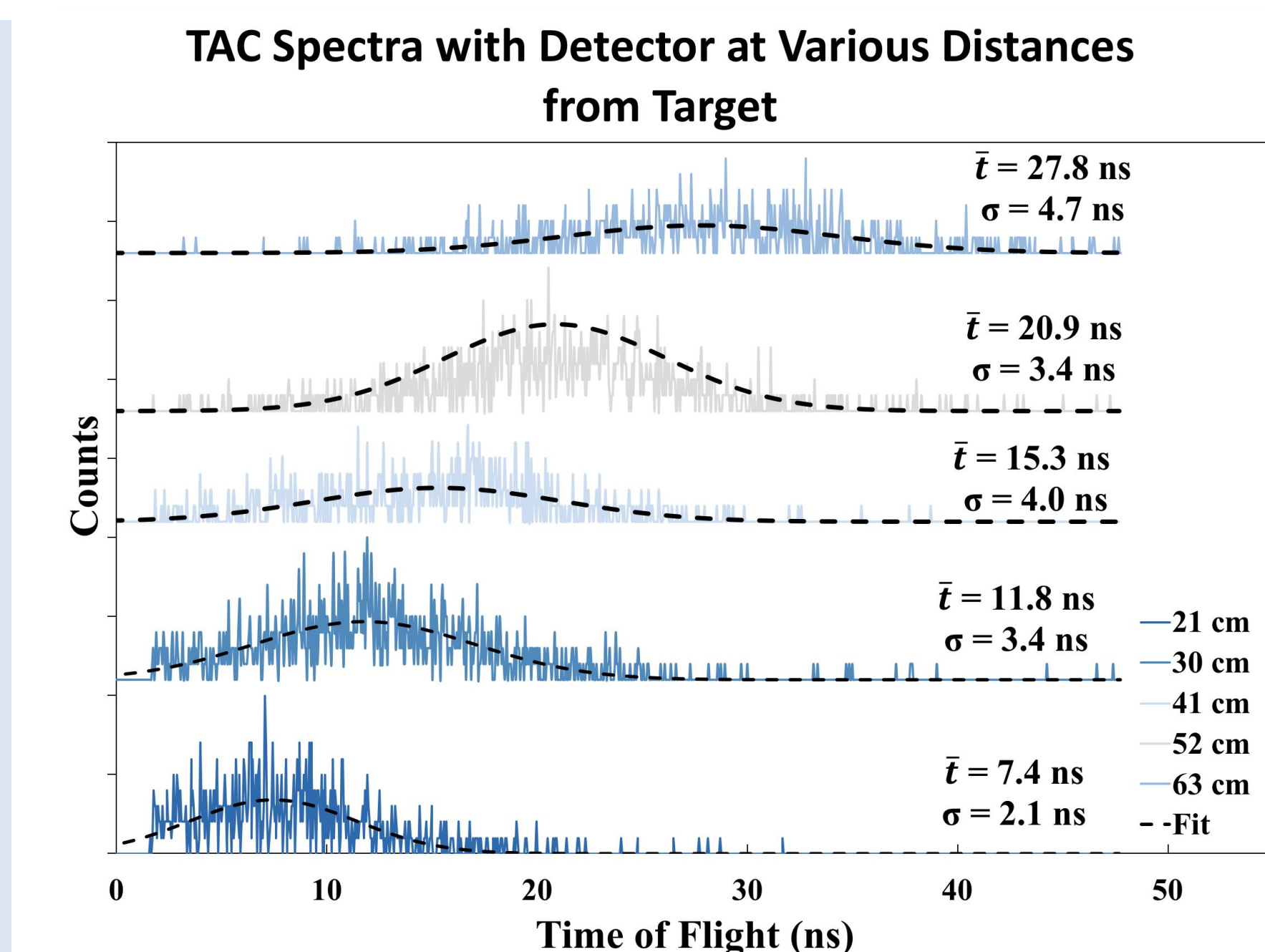

Acknowledgements

Funded in part by the US Department of Energy through the Laboratory for Laser Energetics.