



THE STATE EDUCATION DEPARTMENT / THE UNIVERSITY OF THE STATE OF NEW YORK / ALBANY, NY 12234

Curriculum, Instruction, and Instructional Technology Team - Room 320 EB

www.emsc.nysed.gov/ciaj

email: emscnysmath@mail.nysed.gov

Geometry

Sample Tasks for Integrated Algebra, developed by New York State teachers, are clarifications, further explaining the language and intent of the associated Performance Indicators. These tasks are not test items, nor are they meant for students' use.

Note: There are no Sample Tasks for the Number Sense and Operations, Measurement, and Statistics and Probability Strands. Although there are no Performance Indicators for these strands in this section of the core curriculum, these strands are still part of instruction within the other strands as an ongoing continuum and building process of mathematical knowledge for all students.

Strands	
Process	Content
Problem Solving	Number Sense and Operations
Reasoning and Proof	Algebra
Communication	Geometry
Connections	Measurement
Representation	Statistics and Probability

Problem Solving Strand

Students will build new mathematical knowledge through problem solving.

G.PS.1 Use a variety of problem solving strategies to understand new mathematical content

G.PS.1a

Obtain several different size cylinders made of metal or cardboard. Using stiff paper, construct a cone with the same base and height as each cylinder. Fill the cone with rice, then pour the rice into the cylinder.

Repeat until the cylinder is filled. Record your data.

What is the relationship between the volume of the cylinder and the volume of the corresponding cone?

Collect the class data for this experiment.

Use the data to write a formula for the volume of a cone with radius r and height h .

G.PS.1b

Use a compass or dynamic geometry software to construct a regular dodecagon (a regular 12-sided polygon).

What is the measure of each central angle in the regular dodecagon?

Find the measure of each angle of the regular dodecagon.

Extend one of the sides of the regular dodecagon.

What is the measure of the exterior angle that is formed when one of the sides is extended?

Students will solve problems that arise in mathematics and in other contexts.

G.PS.2 Observe and explain patterns to formulate generalizations and conjectures

G.PS.2a

Examine the diagram of a right triangular prism below.

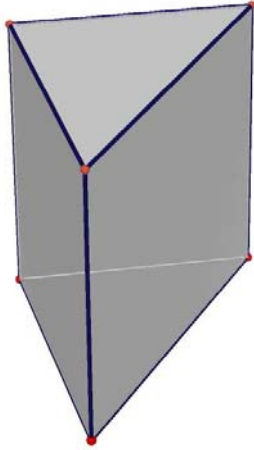

Describe how a plane and the prism could intersect so that the intersection is:

- a line parallel to one of the triangular bases
- a line perpendicular to the triangular bases
- a triangle
- a rectangle
- a trapezoid

G.PS.2b

Use a compass or computer software to draw a circle with center C . Draw a chord \overline{AB} .

Choose and label four points on the circle and on the same side of chord \overline{AB} .

Draw and measure the four angles formed by the endpoints of the chord and each of the four points.

What do you observe about the measures of these angles?

Measure the central angle, $\angle ACB$. Is there any relationship between the measure of an inscribed angle formed using the endpoints of the chord and another point on the circle and the central angle formed using the endpoints of the chord?

Suppose the four points chosen on the circle were on the other side of the chord.

How are the inscribed angles formed using these points and the endpoints of the chord related to the inscribed angles formed in the first question?

G.PS.2c

Consider the following conjecture: The intersection of two distinct planes can be a point. Find a “real world” example that supports the conjecture or provides a counterexample to the conjecture. Share your example with a partner and use your knowledge of geometry in three dimensional space to justify it.

G.PS.2d

Using dynamic geometry software, locate the circumcenter, incenter, orthocenter, and centroid of a given triangle. Use your sketch to answer the following questions:

Do any of the four centers always remain inside the circle?

If a center is moved outside of the triangle, under what circumstances will it happen?

Are the four centers ever collinear? If so, under what circumstances?

Describe what happens to the centers if the triangle is a right triangle.

G.PS.2e

The equation for a reflection over the y -axis, $R_{x=0}$, is $R_{x=0}(x, y) \rightarrow (-x, y)$.

Find a pattern for reflecting a point over another vertical line such as $x = 4$.

Write an equation for reflecting a point over any vertical line $y = k$

G.PS.2f

The equation for a reflection over the x -axis, $R_{y=0}$, is $R_{y=0}(x, y) \rightarrow (x, -y)$.

Find a pattern for reflecting a point over another horizontal line such as $y = 3$.

Write an equation for reflecting a point over any horizontal line $y = h$

G.PS.3 Use multiple representations to represent and explain problem situations (e.g., spatial, geometric, verbal, numeric, algebraic, and graphical representations)

G.PS.3a

Consider the following conjecture: The intersection of two distinct planes can be a point. Find a “real world” example that supports the conjecture or provides a counterexample to the conjecture. Share your example with a partner and use your knowledge of geometry in three dimensional space to justify it.

G.PS.3b

Draw a line on a piece of cardboard. Use additional pieces of cardboard to construct two planes that are perpendicular to the line that you drew. Make a conjecture regarding those two planes and share your example with a partner and use your knowledge of geometry in three dimensional space to justify your conjecture.

G.PS.3c

Determine the point(s) in the plane that are equidistant from the points A(2,6), B(4,4), and C(8,6).

G.PS.3d

In figure 1 a circle is drawn that passes through the point $(-1,0)$. \overline{BS} is perpendicular to the y -axis at B the point where the circle crosses the y -axis. \overline{SC} is perpendicular to the x -axis at the point where C crosses the x -axis. As point S is dragged, the coordinates of point S are collected and stored in L1 and L2 as shown in figure 2. A scatter plot of the data is shown in figure 3 with figure 4 showing the window settings for the graph. Finally a power regression is performed on this data with the resulting function displayed in figure 5 with its equation given in figure 6.

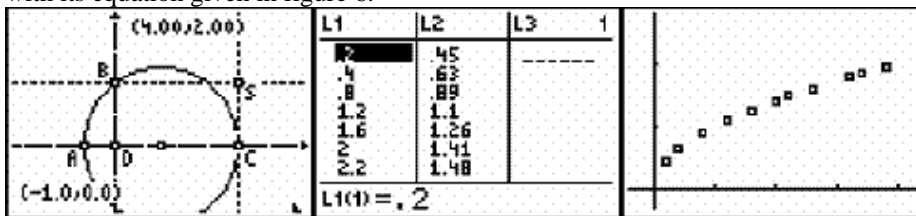

Figure 1

Figure 2

Figure 3

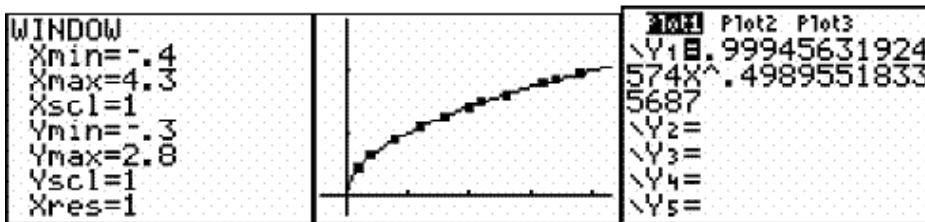

Figure 4

Figure 5

Figure 6

In groups of three or four discuss the results that you see in this activity. Answer the following questions in your group:

Is the function reasonable for this data?

Did you recognize a pattern in the lists of data?

Explain why \overline{DC} and \overline{SC} are related.

What is the significance of A being located at the point (-1,0)?

State the theorem that you have studied that justifies these results.

Students will apply and adapt a variety of appropriate strategies to solve problems.

G.PS.4 Construct various types of reasoning, arguments, justifications and methods of proof for problems

G.PS.4a

Consider a cylinder, a cone, and a sphere that have the same radius and the same height.

Sketch and label each figure.

What is the relationship between the volume of the cylinder and the volume of the cone?

What is the relationship between the volume of the cone and the volume of the sphere?

What is the relationship between the volume of the cylinder and the volume of the sphere?

Use the formulas for the volume of a cylinder, a cone, and a sphere to justify mathematically that the relationships in the previous parts are correct.

G.PS.4b

Use a straightedge to draw an angle and label it $\angle ABC$. Then construct the bisector of $\angle ABC$ by following the procedure outlined below:

Step 1: With the compass point at B , draw an arc that intersects \overrightarrow{BA} and \overrightarrow{BC} . Label the intersection points D and E respectively.

Step 2: With the compass point at D and then at E , draw two arcs with the same radius that intersect in the interior of $\angle ABC$. Label the intersection point F .

Step 3: Draw ray BF .

Write a proof that ray BF bisects $\angle ABC$.

G.PS.4c

Use a straightedge to draw a segment and label it \overline{AB} . Then construct the perpendicular bisector of segment \overline{AB} by following the procedure outlined below:

Step 1: With the compass point at A , draw a large arc with a radius greater than $\frac{1}{2}AB$ but less than the length of AB so that the arc intersects \overline{AB} .

Step 2: With the compass point at B , draw a large arc with the same radius as in step 1 so that the arc intersects the arc drawn in step 1 twice, once above \overline{AB} and once below \overline{AB} . Label the intersections of the two arcs C and D .

Step 3: Draw segment \overline{CD} .

Write a proof that segment \overline{CD} is the perpendicular bisector of segment \overline{AB} .

G.PS.4d

Prove: The bisector of the vertex angle of an isosceles triangle is perpendicular to the base.

G.PS.5 Choose an effective approach to solve a problem from a variety of strategies (numeric, graphic, algebraic)

G.PS.5a

Students in one mathematics class noticed that a local movie theater sold popcorn in different shapes of containers, for different prices. They wondered which of the choices was the best buy. Analyze the three popcorn containers below. Which is the best buy? Explain.

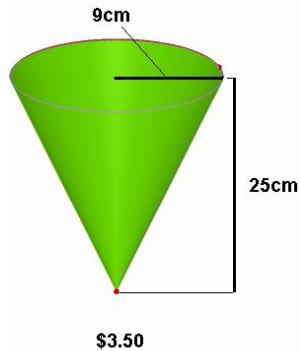
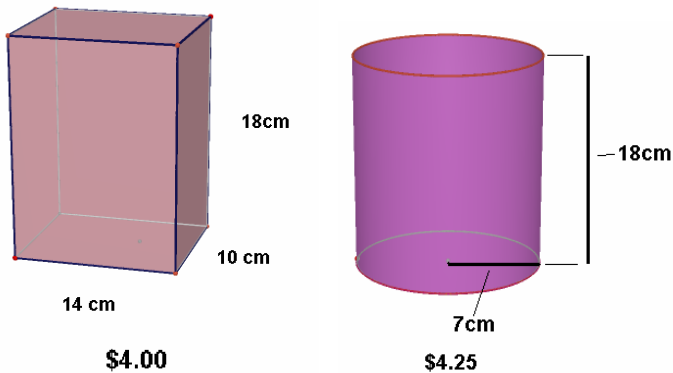

G.PS.5b

Find the number of sides of a regular n -gon that has an exterior angle whose measure is 10°

G.PS.5c

The equations of two lines are $2x + 5y = 3$ and $5x = 2y - 7$. Determine whether these lines are parallel, perpendicular, or neither and explain how you determined your answer.

G.PS.5d

Jeanette invented the rule $A = \frac{(n-2)180}{n}$ to find the measure of A of one angle in a regular n -gon. Do

you think that Jeannette's rule is correct? Justify your reasoning. Use the rule to predict the measure of one angle of a regular 20-gon. As the number of sides of a regular polygon increases, how does the measure of one of its angles change? When will the measure of each angle of a regular polygon be a whole number?

G.PS.6 Use a variety of strategies to extend solution methods to other problems

G.PS.6a

Find the number of sides of a regular n -gon that has an exterior angle whose measure is 10°

G.PS.6b

Jeanette invented the rule $A = \frac{(n-2)180}{n}$ to find the measure of A of one angle in a

regular n -gon. Do you think that Jeannette's rule is correct? Justify your reasoning.

Use the rule to predict the measure of one angle of a regular 20-gon. As the number of sides of a regular polygon increases, how does the measure of one of its angles change? When will the measure of each angle of a regular polygon be a whole number?

G.PS.7 Work in collaboration with others to propose, critique, evaluate, and value alternative approaches to problem solving

G.PS.7a

As a group, examine the four figures below:

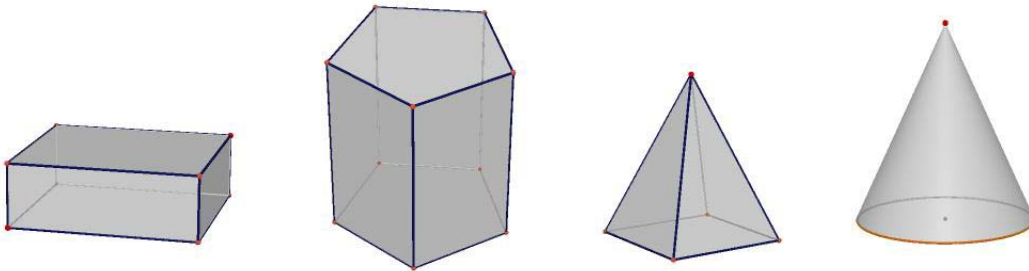

A plane that intersects a three dimensional figure such that one half is the reflected image of the other half is called a *symmetry plane*. Each figure has how many symmetry planes?

Describe the location of all the symmetry planes for each figure within your group. Record your answers.

G.PS.7b

Consider the following conjecture: The intersection of two distinct planes can be a point. Find a “real world” example that supports the conjecture or provides a counterexample to the conjecture. Share your example with a partner and use your knowledge of geometry in three dimensional space to justify it.

G.PS.7c

A *symmetry plane* is a plane that intersects a three-dimensional figure so that one half is the reflected image of the other half. The figure below shows a right hexagonal prism and one of its symmetry planes.

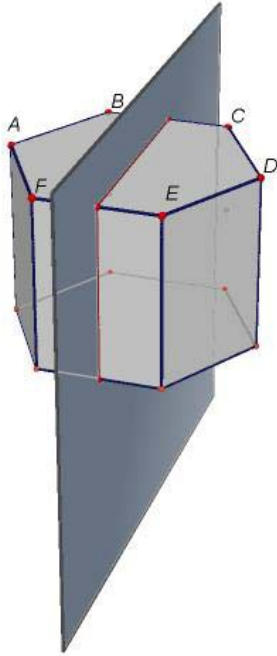

Discuss the following questions:

How is the segment \overline{AD} related to the symmetry plane?

Describe any other segments connecting points on the prism that have the same relationship as segment \overline{AD} to the symmetry plane.

How is segment \overline{BF} related to the symmetry plane?

Describe any other segments connecting points on the prism that have the same relationship as segment \overline{BF} to the symmetry plane.

How are segments \overline{AD} and \overline{BF} related?

G.PS.7d

Within your group use a straightedge to draw an angle and label it $\angle ABC$. Then construct the bisector of $\angle ABC$ by following the procedure outlined below:

Step 1: With the compass point at B , draw an arc that intersects \overrightarrow{BA} and \overrightarrow{BC} . Label the intersection points D and E respectively.

Step 2: With the compass point at D and then at E , draw two arcs with the same radius that intersect in the interior of $\angle ABC$. Label the intersection point F .

Step 3: Draw ray \overrightarrow{BF} .

As a group write a proof that ray BF bisects $\angle ABC$.

Students will monitor and reflect on the process of mathematical problem solving.

G.PS.8 Determine information required to solve a problem, choose methods for obtaining the information, and define parameters for acceptable solutions

G.PS.8a

The Great Pyramid of Giza is a right pyramid with a square base. The measurements of the Great Pyramid include a base b equal to approximately 230 meters and a slant height s equal to approximately 464 meters.

Calculate the current height of the Great Pyramid to the nearest meter.

Calculate the area of the base of the Great Pyramid.

Calculate the volume of the Great Pyramid.

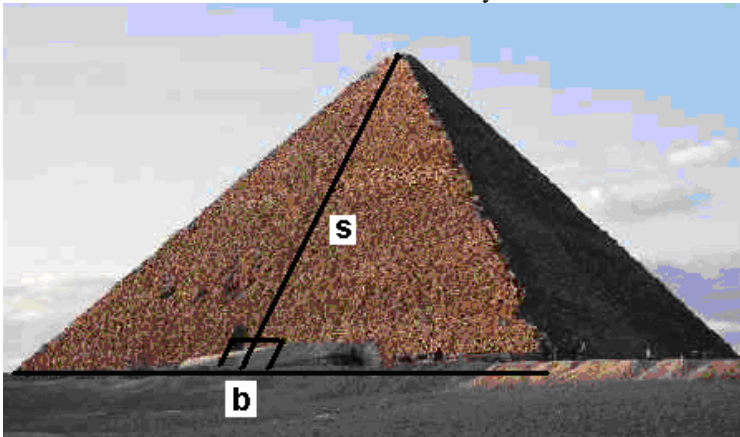

G.PS.8b

A swimming pool in the shape of a rectangular prism has dimensions 26 feet long, 16 feet wide, and 6 feet deep.

How much water is needed to fill the pool to 6 inches from the top?

How many gallons of paint are needed to paint the inside of the pool if one gallon of paint covers approximately 60 square feet?

How much material is needed to make a pool cover that extends 1.5 feet beyond the pool on all sides?

How many 6 inch square tiles are needed to tile the top of the inside faces of the pool?

G.PS.8c

Students in one mathematics class noticed that a local movie theater sold popcorn in different shapes of containers, for different prices. They wondered which of the choices was the best buy. Analyze the three popcorn containers below. Which is the best buy? Explain.

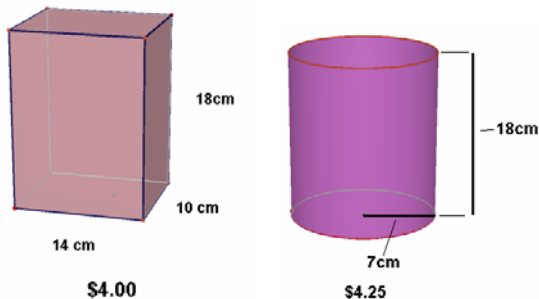

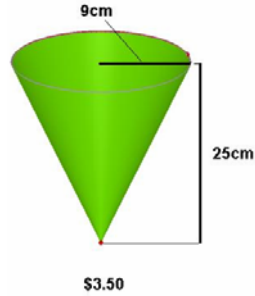

G.PS.9 Interpret solutions within the given constraints of a problem

G.PS.9a

A manufacturing company is charged with designing a can that is to be constructed in the shape of a right circular cylinder. The only requirements are that the can must be airtight, hold at least 23 cubic inches and should require as little material as possible to construct. Each of the following cans was submitted for consideration by the engineering department.

Which can would you choose to produce?

Justify your choice.

Proposal #1

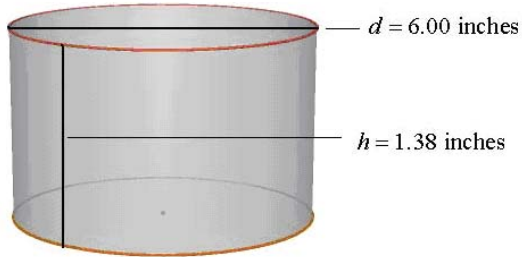

Proposal #2

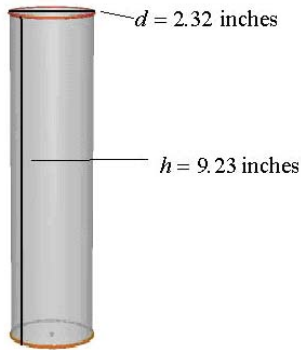

Proposal #3

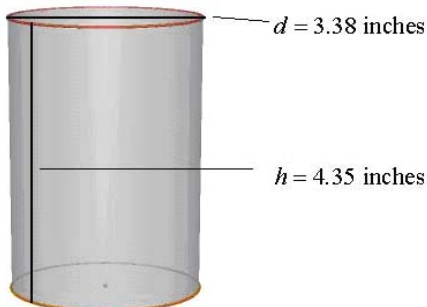

G.PS.9b

A swimming pool in the shape of a rectangular prism has dimensions 26 feet long, 16 feet wide, and 6 feet deep.

How much water is needed to fill the pool to 6 inches from the top?

How many gallons of paint are needed to paint the inside of the pool if one gallon of paint covers approximately 60 square feet?

How much material is needed to make a pool cover that extends 1.5 feet beyond the pool on all sides?

How many 6 inch square tiles are needed to tile the top of the inside faces of the pool?

G.PS.9c

Use the information given in the diagram to determine the measure of $\angle ACB$.

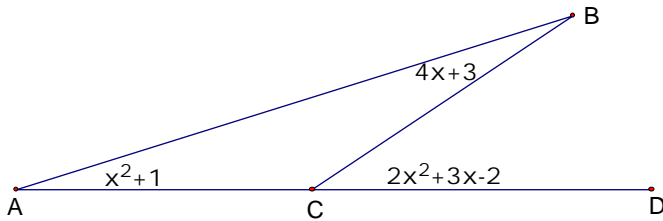

G.PS.10 Evaluate the relative efficiency of different representations and solution methods of a problem

G.PS.10a

The equations of two lines are $2x + 5y = 3$ and $5x = 2y - 7$. Determine whether these lines are parallel, perpendicular, or neither and explain how you determined your answer.

Compare your answer with others. As a class discuss the relative efficiency of the different representations and solution methods.

G.PS.10b

Consider the following theorem: The diagonals of a parallelogram bisect each other. Write three separate proofs for the theorem, one using synthetic techniques, one using analytical techniques, and one using transformational techniques. Discuss with the class the relative strengths and weakness of each of the different approaches.

[Back to top](#)

Reasoning and Proof

Students will recognize reasoning and proof as fundamental aspects of mathematics.

G.RP.1 Recognize that mathematical ideas can be supported by a variety of strategies

G.RP.1a

Investigate the two drawings using dynamic geometry software. Write as many conjectures as you can for each drawing.

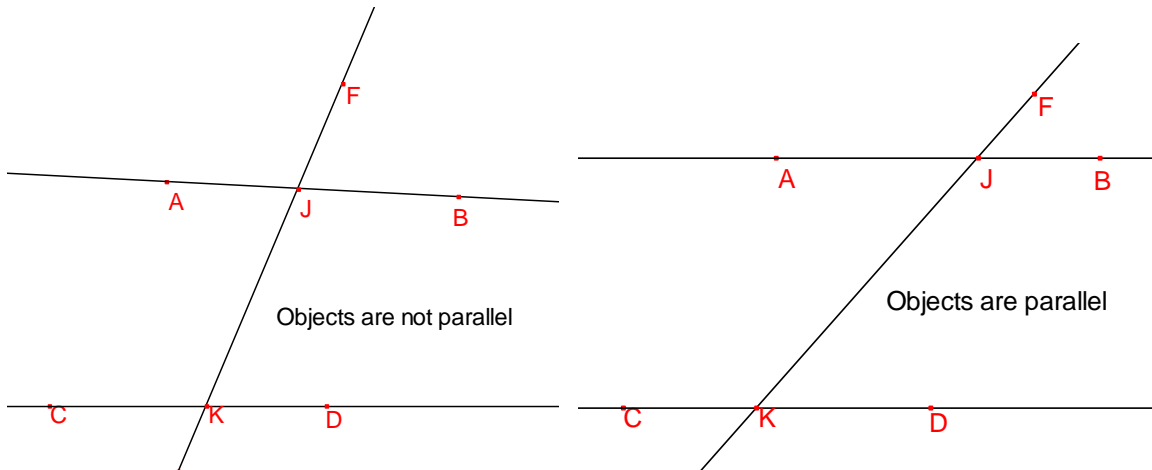

G.RP.2 Recognize and verify, where appropriate, geometric relationships of perpendicularity, parallelism, congruence, and similarity, using algebraic strategies

G.RP.2a

Examine the diagram of a pencil below:



The pencil is an example of what three-dimensional shape?
 How can the word *parallel* be used to describe features of the pencil?
 How can the word *perpendicular* be used to describe features of the pencil?

G.RP.2b

The figure below is a right hexagonal prism.

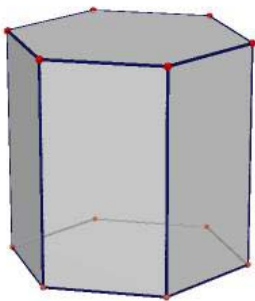

A *symmetry plane* is a plane that intersects a three dimensional figure so that one half is the reflected image of the other half. On a copy of the figure sketch a symmetry plane.

Then write a description that uses the word *parallel*.

On a copy of the figure sketch another symmetry plane. Then write a description that uses the word *perpendicular*.

G.RP.2c

What changes the volume of a cylinder more, doubling the diameter or doubling the height? Provide evidence for your conjecture. Then write a mathematical argument for why your conjecture is true.

Students will make and investigate mathematical conjectures.

G.RP.3 Investigate and evaluate conjectures in mathematical terms, using mathematical strategies to reach a conclusion

G.RP.3a

Consider the following conjecture: The intersection of two distinct planes can be a point. Find a “real world” example that supports the conjecture or provides a counterexample to the conjecture. Share your example with a partner and use your knowledge of geometry in three dimensional space to justify it.

G.RP.3b

Jeanette invented the rule $A = \frac{(n-2)180}{n}$ to find the measure of A of one angle in a

regular n -gon. Do you think that Jeannette’s rule is correct? Justify your reasoning.

Use the rule to predict the measure of one angle of a regular 20-gon. As the number of sides of a regular polygon increases, how does the measure of one of its angles change? When will the measure of each angle of a regular polygon be a whole number?

G.RP.3c

A rectangular gift box with whole number dimensions has a volume of 36 cubic inches.

Find the dimensions of all possible boxes. Determine the box that would require the least amount of wrapping paper.

Find the dimensions of all possible boxes if the volume is 30 cubic inches. Determine the box that would require the least amount of wrapping paper.

Write a conjecture about the dimensions of a rectangular box with any fixed volume that would require the least amount of wrapping paper. Write a mathematical argument for why your conjecture is true.

G.RP.3d

What changes the volume of a cylinder more, doubling the diameter or doubling the height? Provide evidence for your conjecture. Then write a mathematical argument for why your conjecture is true.

G.RP.3e

Construct an angle of 30° and justify your construction.

Students will develop and evaluate mathematical arguments and proofs.

G.RP.4 Provide correct mathematical arguments in response to other students’ conjectures, reasonings, and arguments

G.RP.4a

Draw a line on a piece of cardboard. Use additional pieces of cardboard to construct two planes that are perpendicular to the line that you drew. Make a conjecture regarding those two planes and justify your conjecture. Discuss as a group.

G.RP.4b

Given acute triangles $\triangle PQR$ and $\triangle STU$ with $\angle RPQ \cong \angle UST$, $\overline{PQ} \cong \overline{ST}$, and $\overline{QR} \cong \overline{TU}$. Norman claims that he can prove $\triangle PQR \cong \triangle STU$ using Side-Side-Angle congruence. Is Norman correct? Explain your conclusion to Norman.

G.RP.5 Present correct mathematical arguments in a variety of forms

G.RP.5a

Use a straightedge to draw a segment and label it \overline{AB} . Then construct the perpendicular bisector of segment \overline{AB} by following the procedure outlined below:

Step 1: With the compass point at A , draw a large arc with a radius greater than $\frac{1}{2}AB$ but less than the length of AB so that the arc intersects \overline{AB} .

Step 2: With the compass point at B , draw a large arc with the same radius as in step 1 so that the arc intersects the arc drawn in step 1 twice, once above \overline{AB} and once below \overline{AB} . Label the intersections of the two arcs C and D .

Step 3: Draw segment \overline{CD} .

Write a proof that segment \overline{CD} is the perpendicular bisector of segment AB .

G.RP.5b

Justify the fact that if one edge of a triangular prism is perpendicular to its base then the prism is a right triangular prism.

G.RP.5c

Construct an angle of 30° and justify your construction.

G.RP.5d

Prove that if a radius of a circle passes through the midpoint of a chord, then it is perpendicular to that chord. Discuss your proof with a partner.

G.RP.5e

Using dynamic geometry, draw a circle and its diameter. Through an arbitrary point on the diameter (not the center of the circle) construct a chord perpendicular to the diameter. Drag the point to different locations on the diameter and make a conjecture. Discuss your conjecture with a partner.

G.RP.6 Evaluate written arguments for validity

G.RP.6a

A rectangular gift box with whole number dimensions has a volume of 36 cubic inches.

Find the dimensions of all possible boxes. Determine the box that would require the least amount of wrapping paper.

Find the dimensions of all possible boxes if the volume is 30 cubic inches. Determine the box that would require the least amount of wrapping paper.

Write a conjecture about the dimensions of a rectangular box with any fixed volume that would require the least amount of wrapping paper.

Write a mathematical argument for why your conjecture is true.

Compare your arguments with a partner and discuss the validity of each argument.

G.RP.6b

Prove that a quadrilateral whose diagonals bisect each other must be a parallelogram.

Compare your arguments with a partner and discuss the validity of each argument.

G.RP.6c

Prove that if a radius of a circle passes through the midpoint of a chord, then it is perpendicular to that chord. Discuss your proof with a partner.

Compare your arguments with a partner and discuss the validity of each argument.

G.RP.6d

Prove that a quadrilateral whose diagonals are perpendicular bisectors of each other must be a rhombus.

Compare your arguments with a partner and discuss the validity of each argument.

Students will select and use various types of reasoning and methods of proof.

G.RP.7 Construct a proof using a variety of methods (e.g., deductive, analytic, transformational)

G.RP.7a

Use a straightedge to draw a segment and label it \overline{AB} . Then construct the perpendicular bisector of segment \overline{AB} by following the procedure outlined below:

Step 1: With the compass point at A , draw a large arc with a radius greater than $\frac{1}{2}AB$ but less than the length of AB so that the arc intersects \overline{AB} .

Step 2: With the compass point at B , draw a large arc with the same radius as in step 1 so that the arc intersects the arc drawn in step 1 twice, once above \overline{AB} and once below \overline{AB} . Label the intersections of the two arcs C and D .

Step 3: Draw segment \overline{CD} .

Write a proof that segment \overline{CD} is the perpendicular bisector of segment \overline{AB} .

G.RP.7b

Consider the theorem below. Write three separate proofs for the theorem, one using synthetic techniques, one using analytical techniques, and one using transformational techniques. Discuss the strengths and weakness of each of the different approaches.

The diagonals of a parallelogram bisect each other.

G.RP.7b

Prove: The bisector of the vertex angle of an isosceles triangle is perpendicular to the base.

G.RP.8 Devise ways to verify results or use counterexamples to refute incorrect statements

G.RP.8a

Consider the following conjecture: The intersection of two distinct planes can be a point. Find a “real world” example that supports the conjecture or provides a counterexample to the conjecture. Share your example with a partner and use your knowledge of geometry in three dimensional space to justify it.

G.RP.8b

Examine the diagonals of each type of quadrilateral (parallelogram, rhombus, square, rectangle, kite, trapezoid, and isosceles trapezoid).

For which of these quadrilaterals are the diagonals also lines of symmetry?

For the quadrilaterals whose diagonals are lines of symmetry, identify other properties that are a direct result of the symmetry.

Which quadrilaterals have congruent diagonals?

Are the diagonals in these quadrilaterals also lines of symmetry?

Explain your answers.

G.RP.9 Apply inductive reasoning in making and supporting mathematical conjectures

G.RP.9a

Examine the diagram of a pencil below:



Explain how the pencil illustrates the fact that if two lines are perpendicular to the same line, then they must be parallel.

Explain how the pencil illustrates the fact that if two lines are parallel, then they must be perpendicular to the same line.

G.RP.9b

Examine the diagram of a right triangular prism below:

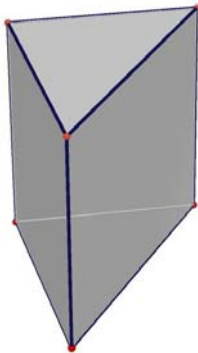

Describe how a plane and the prism could intersect so that the intersection is:

- a line parallel to one of the triangular bases
- a line perpendicular to the triangular bases
- a triangle
- a rectangle
- a trapezoid

G.RP.9c

Analyze the following changes in dimensions of three-dimensional figures to predict the change in the corresponding volumes.

- One soup can has dimensions that are twice those of a smaller can.
- One box of pasta has dimensions that are three times the dimensions of a smaller box.
- The dimensions of one cone are five times the dimensions of another cone.
- The dimensions of one triangular prism are x times the dimensions of another triangular prism.

[Back to top](#)

Communications

Students will organize and consolidate their mathematical thinking through communication.

G.CM.1 Communicate verbally and in writing a correct, complete, coherent, and clear design (outline) and explanation for the steps used in solving a problem

G.CM.1a

Jim is a carpenter and would like to install a flagpole in his front yard. Carpenters use a tool called a level, shown in the figure below, to determine if objects are level (horizontal) or plumb (vertical). Describe how Jim can use a level to ensure that the flagpole appears vertical from any direction.

Explain why your procedure works.

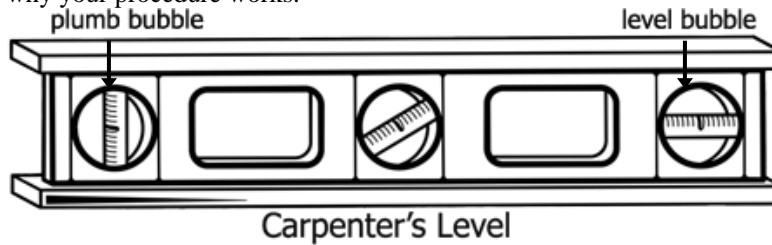

G.CM.1b

In the accompanying diagram, figure $ABCD$ is a parallelogram and \overline{AC} and \overline{BD} are diagonals that intersect at point E . Working with a partner determine at least two pairs of triangles that are congruent and discuss which properties of a parallelogram are necessary to prove that the triangles are congruent. Write a plan for proving that the triangles you chose are congruent.

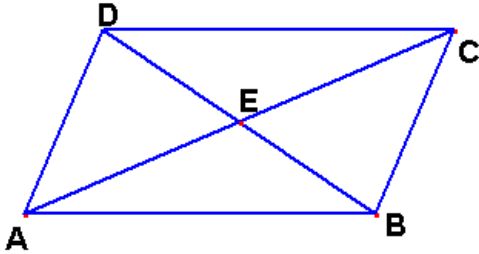

G.CM.1c

Using dynamic geometry software locate the circumcenter, incenter, orthocenter, and centroid of a given triangle. Use your sketch to answer the following questions:

Do any of the four centers always remain inside the circle?

If a center is moved outside the triangle, under what circumstances will it happen?

Are the four centers every collinear? If so, under what circumstances?

Describe what happens to the centers if the triangle is a right triangle.

G.CM.1d

In the accompanying diagram figure $PQRS$ is an isosceles trapezoid and \overline{PR} and \overline{QS} are diagonals that intersect at point T . Working with a partner, determine a pair of triangles that are congruent and state which properties of an isosceles trapezoid are necessary to prove that the triangles are congruent. Write a plan for proving the triangles you chose are congruent.

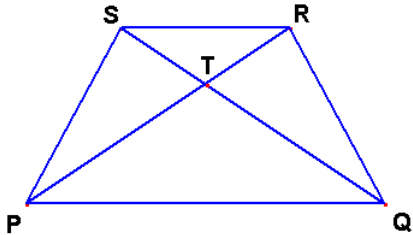

G.CM.1e

Prove: The bisector of the vertex angle of an isosceles triangle is perpendicular to the base.

G.CM.2 Use mathematical representations to communicate with appropriate accuracy, including numerical tables, formulas, functions, equations, charts, graphs, and diagrams

G.CM.2a

Determine the points in the plane that are equidistant from the points A(2,6), B(4,4), and C(8,6).

G.CM.2b

Jeanette invented the rule $A = \frac{(n-2)180}{n}$ to find the measure of A of one angle in a regular n -gon. Do you

think that Jeanette's rule is correct? Justify your reasoning.

Use the rule to predict the measure of one angle of a regular 20-gon. As the number of sides of a regular polygon increases, how does the measure of one of its angles change? When will the measure of each angle of a regular polygon be a whole number?

G.CM.2c

The following graphic is a stop sign.



regular octagon

What is the sum of the measures of the angles of a *stop* sign?

What is the measure of each of the angles of a *stop* sign?

What is the measure of an exterior angle of a *stop* sign?

Describe all the symmetries of a *stop* sign.

G.CM.2d

In figure 1 a circle is drawn that passes through the point $(-1,0)$. \overline{BS} is perpendicular to the y-axis at B the point where the circle crosses the y-axis. \overline{SC} is perpendicular to the x-axis at the point where C crosses the x-axis. A point S is dragged, the coordinates of point S are collected and stored in L1 and L2 as shown in figure 2. A scatter plot of the data is shown in figure 3 with figure 4 showing the window settings for the graph. Finally a power regression is performed on this data with the resulting function displayed in figure 5 with its equation given in figure 6.

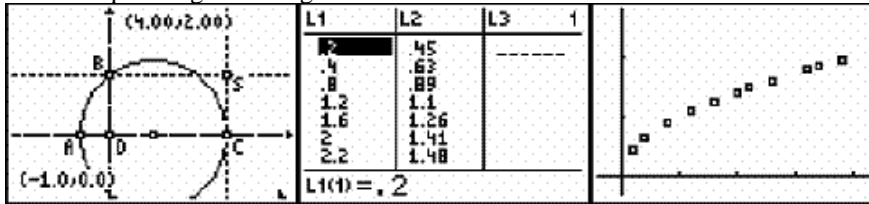

Figure 1

Figure 2

Figure 3

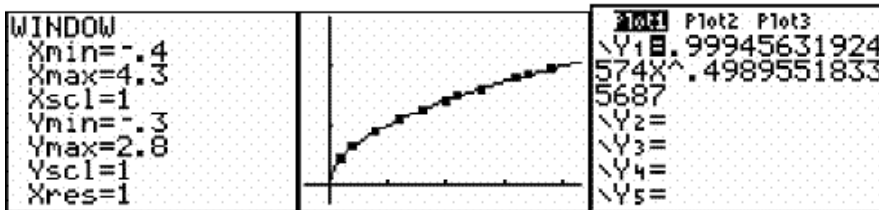

Figure 4

Figure 5

Figure 6

In groups of three or four discuss the results that you see in this activity. Answer the following questions in your group.

Is the function reasonable for this data?

Did you recognize a pattern in the lists of data?

Explain why \overline{DC} and \overline{SC} are related.

What is the significance of A being located at the point $(-1,0)$?

State the theorem that you have studied that justifies these results.

Students will communicate their mathematical thinking coherently and clearly to peers, teachers, and others.

G.CM.3 Present organized mathematical ideas with the use of appropriate standard notations, including the use of symbols and other representations when sharing an idea in verbal and written form

G.CM.3a

Julie wishes to construct a wall in the basement of her apartment. Describe what she must do to ensure that the wall is perpendicular to the floor of the basement. Explain why Julie's procedure will work, using appropriate mathematical terminology.

G.CM.3b

The figure below shows rectangle ABCD with triangle BEC. If $DC = 2AD$, $BE = AB$, and $CE > CD$, determine the largest angle of triangle BEC.

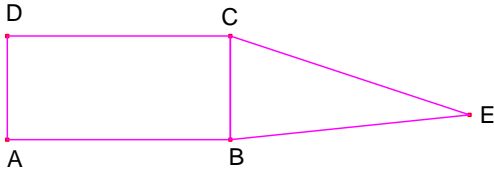

G.CM.3c

Consider the figure below. Write using proper notation, a composition of transformations that will map triangle $\triangle ABC$ onto $\triangle A'B'C'$.

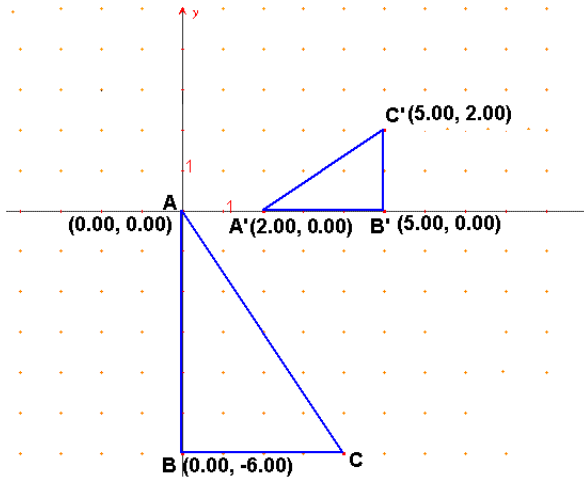

G.CM.4 Explain relationships among different representations of a problem

G.CM.4a

Consider the theorem below. Write three separate proofs for the theorem, one using synthetic techniques, one using analytical techniques, and one using transformational techniques. Discuss the strengths and weakness of each of the different approaches.

The diagonals of a parallelogram bisect each other.

G.CM.5 Communicate logical arguments clearly, showing why a result makes sense and why the reasoning is valid

G.CM.5a

A manufacturing company is charged with designing a can that is to be constructed in the shape of a right circular cylinder. The only requirements are that the can must be airtight, hold at least 23 cubic inches and should require as little material as possible to construct. Each of the following cans was submitted for consideration by the engineering department.

Which can would you choose to produce?

Justify your choice.

Proposal #1

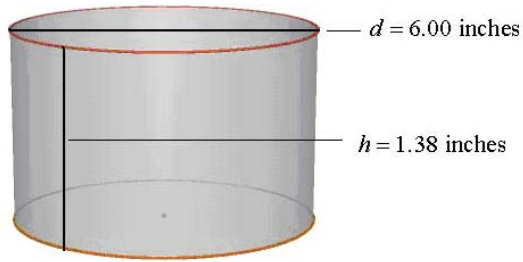

Proposal #2

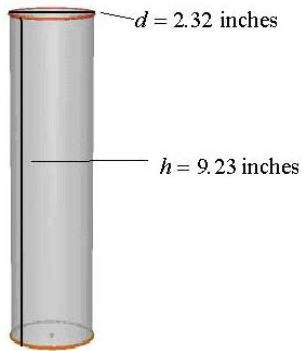

Proposal #3

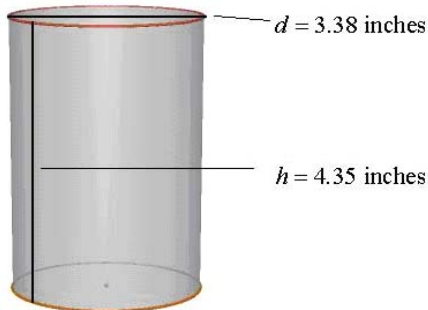

G.CM.5b

A rectangular gift box with whole number dimensions has a volume of 36 cubic inches.

Find the dimensions of all possible boxes. Determine the box that would require the least amount of wrapping paper.

Find the dimensions of all possible boxes if the volume is 30 cubic inches. Determine the box that would require the least amount of wrapping paper.

Write a conjecture about the dimensions of a rectangular box with any fixed volume that would require the least amount of wrapping paper. To cover the box write a mathematical argument for why your conjecture is true.

G.CM.5c

What changes the volume of a cylinder more, doubling the diameter or doubling the height? Provide evidence for your conjecture. Then write a mathematical argument for why your conjecture is true.

G.CM.5d

Use a straightedge to draw an angle and label it $\angle ABC$. Then construct the bisector of $\angle ABC$ by following the procedure outlined below.

Step 1: With the compass point at B , draw an arc that intersects \overrightarrow{BA} and \overrightarrow{BC} . Label the intersection points D and E respectively.

Step 2: With the compass point at D and then at E , draw two arcs with the same radius that intersect in the interior of $\angle ABC$. Label the intersection point F .

Step 3: Draw ray \overrightarrow{BF} .

Write a proof that ray \overrightarrow{BF} bisects $\angle ABC$.

G.CM.5e

Construct an angle of 30° and justify your construction.

G.CM.6 Support or reject arguments or questions raised by others about the correctness of mathematical work

G.CM.6a

Prove that a quadrilateral whose diagonals bisect each other must be a parallelogram to the class. Be prepared to defend your work.

G.CM.6b

Prove that a quadrilateral whose diagonals are perpendicular bisectors of each other must be a rhombus to the class. Be prepared to defend your work.

Students will analyze and evaluate the mathematical thinking and strategies of others.

G.CM.7 Read and listen for logical understanding of mathematical thinking shared by other students

G.CM.7a

Consider the following conjecture: The intersection of two distinct planes can be a point. Find a “real world” example that supports the conjecture or provides a counterexample to the conjecture. Share your example with a partner and use your knowledge of geometry in three dimensional space to justify it.

G.CM.7b

Draw a line on a piece of cardboard. Use additional pieces of cardboard to construct two planes that are perpendicular to the line that you drew. Make a conjecture regarding those two planes and justify your conjecture.

GCM.7c

The equations for a reflection over the x -axis, $R_{y=0}$, are $R_{y=0}(x, y) \rightarrow (x, -y)$.

Find a pattern for reflecting a point over another horizontal line such as $y = 3$.

Write a rule for reflecting a point over any horizontal line $y = h$. Explain your rule to another student and compare your rules.

G.CM.8 Reflect on strategies of others in relation to one’s own strategy

G.CM.8a

In a group, prove that a quadrilateral whose diagonals bisect each other must be a parallelogram. Discuss all the strategies needed to communicate this proof to another group

G.CM.8b

In a group, prove that a quadrilateral whose diagonals are perpendicular bisectors of each other must be a rhombus. Discuss all the strategies needed to communicate this proof to another group.

G.CM.9 Formulate mathematical questions that elicit, extend, or challenge strategies, solutions, and/or conjectures of others

G.CM.9a

Draw a line on a piece of cardboard. Use additional pieces of cardboard to construct two planes that are perpendicular to the line that you drew. Make a conjecture regarding those two planes and justify your conjecture.

G.CM.9b

Use cardboard to build a model that illustrates two planes perpendicular which are perpendicular to a third plane. Under what conditions will these two planes be parallel? Share your answer with a partner and use your knowledge of geometry in three dimensional space to justify your conjecture.

G.CM.9c

Jose conjectures that in the figure below $\triangle A'BC'$ is the image of $\triangle ABC$ under a reflection in some line. Explain whether Jose's conjecture is correct.

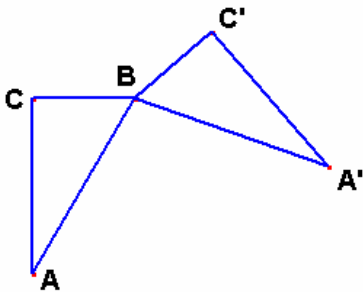

Students will use the language of mathematics to express mathematical ideas precisely.

G.CM.10 Use correct mathematical language in developing mathematical questions that elicit, extend, or challenge other students' conjectures

G.CM10a

Study the drawing below of a pyramid whose base is quadrilateral $ABCD$. John claims that line segment \overline{EF} is the altitude of the pyramid. Explain what John must do to prove to you that he is correct.

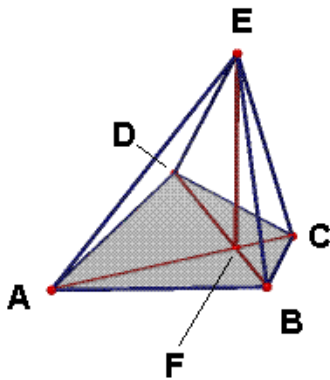

G.CM.10b

Consider the following theorem: The diagonals of a parallelogram bisect each other. Write three separate proofs for the theorem, one using synthetic techniques, one using analytical techniques, and one using transformational techniques. Discuss with the class the relative strengths and weakness of each of the different approaches.

G.CM.11 Understand and use appropriate language, representations, and terminology when describing objects, relationships, mathematical solutions, and geometric diagrams

G.CM.11a

Examine the diagram of a pencil below:



The pencil is an example of what three-dimensional shape?

How can the word *parallel* be used to describe features of the pencil?

How can the word *perpendicular* be used to describe features of the pencil?

G.CM.11b

Examine the two drawings using dynamic geometry software. Write as many conjectures as you can for each drawing.

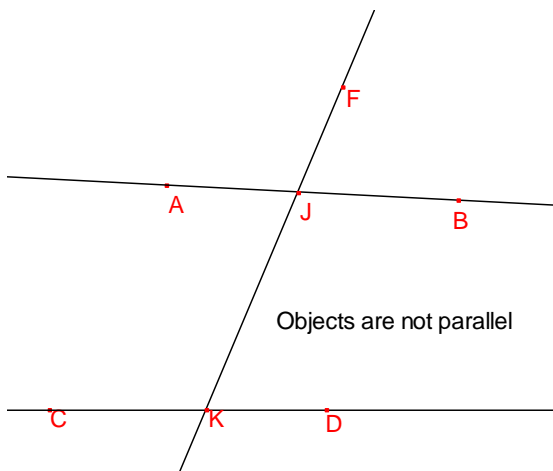

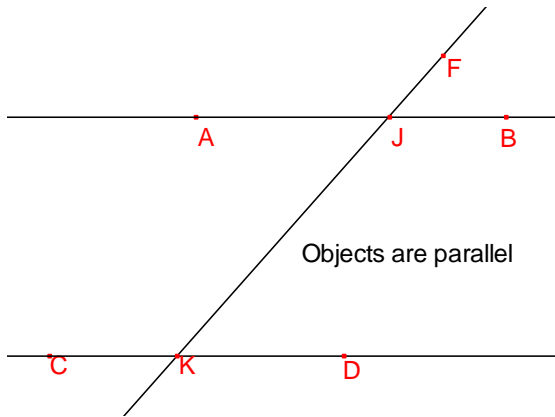

G.CM.12 Draw conclusions about mathematical ideas through decoding, comprehension, and interpretation of mathematical visuals, symbols, and technical writing

G.CM.12a

Examine the diagram of a right triangular prism.

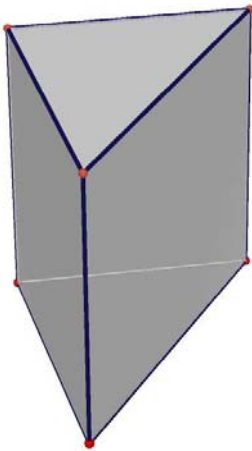

Describe how a plane and the prism could intersect so that the intersection is:

- a line parallel to one of the triangular bases
- a line perpendicular to the triangular bases
- a triangle
- a rectangle
- a trapezoid

G.CM.12b

Consider a cylinder, a cone, and a sphere that have the same radius and the same height.

Sketch and label each figure.

What is the relationship between the volume of the cylinder and the volume of the cone?

What is the relationship between the volume of the cone and the volume of the sphere?

What is the relationship between the volume of the cylinder and the volume of the sphere?

Use the formulas for the volume of a cylinder, a cone, and a sphere to justify mathematically that the relationships are correct.

[Back to top](#)

Connections

Students will recognize and use connections among mathematical ideas.

G.CN.1 Understand and make connections among multiple representations of the same mathematical idea

G.CN.1a

Analyze the following changes in dimensions of three dimensional figures to predict the change in the corresponding volumes:

One soup can has dimensions that are twice those of a smaller can.

One box of pasta has dimensions that are three times the dimensions of a smaller box.

The dimensions of one cone are five times the dimensions of another cone.

The dimensions of one triangular prism are x times the dimensions of another triangular prism.

G.CN.1b

In coordinate geometry the following three statements represent different definitions for the slope of a line:

$$(i) \frac{\text{rise}}{\text{run}}, (ii) \frac{\text{change in } y}{\text{change in } x}, \text{ and } (iii) \text{ tangent of the angle of inclination.}$$

Explain any connections that exists among these definitions.

G.CN.2 Understand the corresponding procedures for similar problems or mathematical concepts

G.CN.2a

Obtain several different size cylinders made of metal or cardboard. Using stiff paper, construct a cone with the same base and height as each cylinder. Fill the cone with rice, then pour the rice into the cylinder.

Repeat until the cylinder is filled. Record your data.

What is the relationship between the volume of the cylinder and the volume of the corresponding cone?

Collect the class data for this experiment.

Use the data to write a formula for the volume of a cone with radius r and height h .

G.CN.2b

Use a compass or dynamic geometry software to construct a regular dodecagon (a regular 12-sided polygon).

What is the measure of each central angle in the regular dodecagon?

Find the measure of each angle of the regular dodecagon.

Extend one of the sides of the regular dodecagon.

What is the measure of the exterior angle that is formed when one of the sides is extended?

Students will understand how mathematical ideas interconnect and build on one another to produce a coherent whole.

G.CN.3 Model situations mathematically, using representations to draw conclusions and formulate new situations

G.CN.3a

Consider the following problem:

Find the dimensions of a rectangular field that can be constructed using exactly 100m of fencing and that has the maximum enclosed area possible. Model the problem using dynamic geometry software and make a conjecture.

G.CN.4 Understand how concepts, procedures, and mathematical results in one area of mathematics can be used to solve problems in other areas of mathematics

G.CN.4a

The accompanying diagram represents a 50 inch diameter archery target. If an arrow hits the target, what is the probability that it hits the yellow “bulls-eye” (the five inch radius center circle)? What is the probability that it hits the red ring?

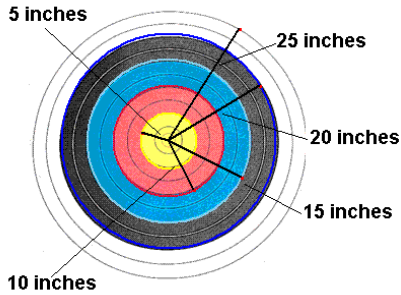

G.CN.4b

Find the number of sides of a regular n -gon that has an exterior angle whose measure is 10°

G.CN.5 Understand how quantitative models connect to various physical models and representations

G.CN.5a

Use dynamic geometry software to draw a circle. Measure its diameter and its circumference and record your results. Create a circle of different size, measure its diameter and circumference, and record your results. Repeat this process several more times. Use the data and a calculator to investigate the relationship between the diameter and circumference of a circle.

Students will recognize and apply mathematics in contexts outside of mathematics.

G.CN.6 Recognize and apply mathematics to situations in the outside world

G.CN.6a

A manufacturing company is charged with designing a can that is to be constructed in the shape of a right circular cylinder. The only requirements are that the can must be airtight, hold at least 23 cubic inches and should require as little material as possible to construct. Each of the following cans was submitted for consideration by the engineering department.

Which can would you choose to produce?
Justify your choice.

Proposal #1

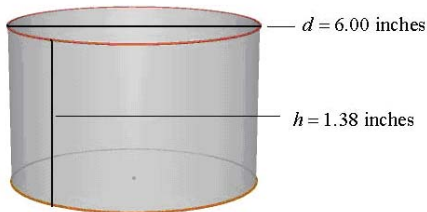

Proposal #2

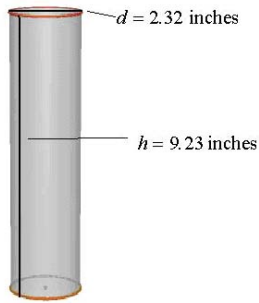

Proposal #3

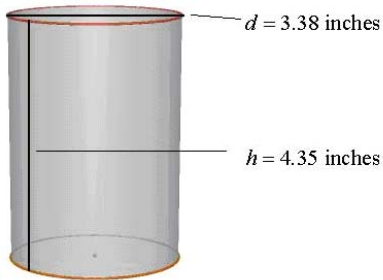

G.CN.6b

Julie wishes to construct a wall in the basement of her apartment. (a) Describe what she must do to ensure that the wall is perpendicular to the floor of the basement. (b) Explain why Julie's procedure will work, using appropriate mathematical terminology.

G.CN.6c

Point A, B, and C represent three cities. A regional transportation center is to be located so that the distance to each city is the same. Where should the transportation center be located? Explain your answer.

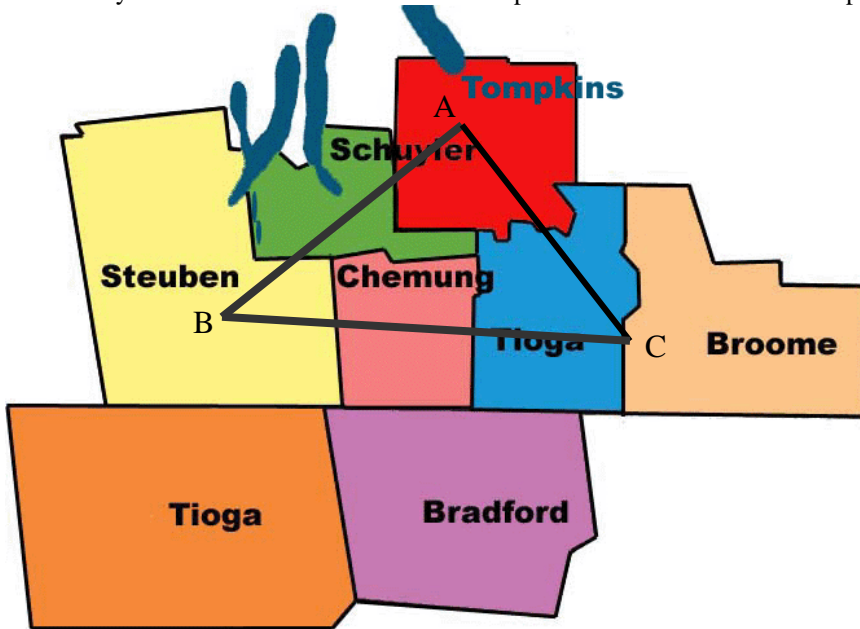

G.CN.6d

The figure below shows the layout of a soccer field. Describe its symmetry. Why do you think this field has this type of symmetry?



G.CN.7 Recognize and apply mathematical ideas to problem situations that develop outside of mathematics

G.CN.7a

Students in one mathematics class noticed that a local movie theater sold popcorn in different shapes of containers, for different prices. They wondered which of the choices was the best buy? Analyze the three popcorn containers below. Which is the best buy? Explain.

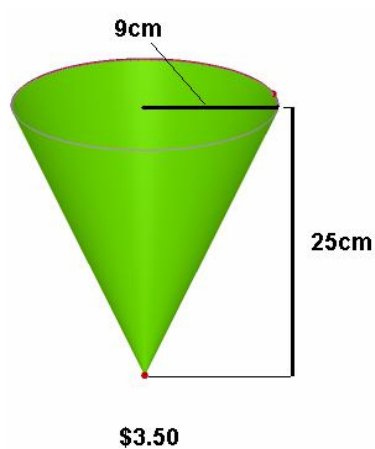
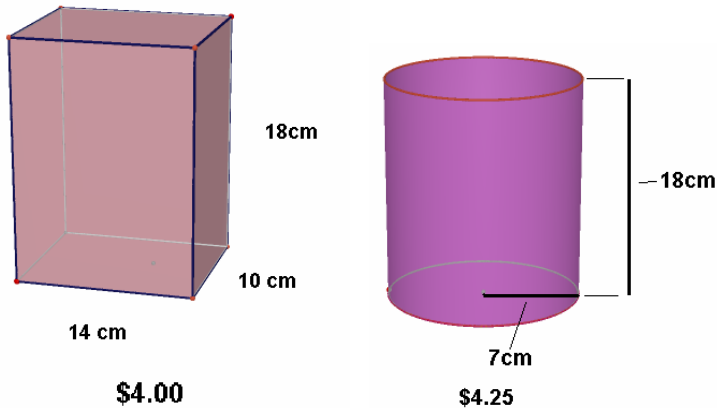

G.CN.7b

A manufacturing company is charged with designing a can that is to be constructed in the shape of a right circular cylinder. The only requirements are that the can must be airtight, hold at least 23 cubic inches and should require as little material as possible to construct. Each of the following cans was submitted for consideration by the engineering department.

Which can would you choose to produce?

Justify your choice.

Proposal #1

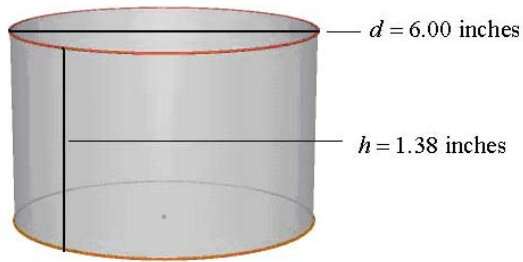

Proposal #2

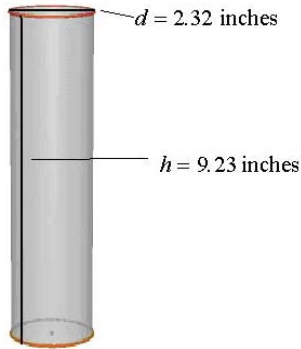

Proposal #3

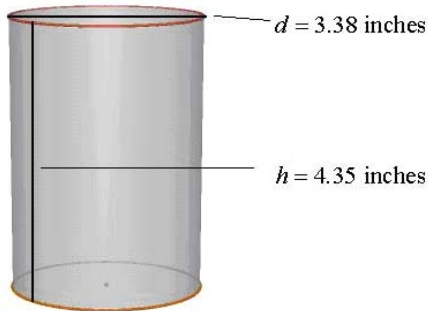

G.CN.8 Develop an appreciation for the historical development of mathematics

G.CN.8a

An Egyptian document, the Rhind Papyrus (ca 1650 B.C.), states that the area of a circle can be determined by finding the area of a square whose side is $\frac{8}{9}$ the diameter of the circle. Is this correct? What value of π is implied by this result?

G.CN.8b

If a and b are the legs of a right triangle and c is the length of the hypotenuse, Babylonian geometers approximated the length of the hypotenuse by the formula $c = b + \left(\frac{a^2}{2b}\right)$. How does this approximation compare to the actual results when $a = 3$ and $b = 4$? When $a = 5$ and $b = 7$? In general, is the approximation too large or too small?

G.CN.8c

In *The Elements*, Euclid stated his parallel postulate as follows: *If a transversal falling on two straight lines makes the interior angles on the same side less than 180° , then the line if produced indefinitely will meet on that side of the transversal where the angles add to less than 180° .* Explain how this statement is related to parallel lines.

[Back to top](#)

Representation

Students will create and use representations to organize, record, and communicate mathematical ideas.

G.R.1 Use physical objects, diagrams, charts, tables, graphs, symbols, equations, or objects created using technology as representations of mathematical concepts

G.R.1a

Examine the accompanying diagram of a pencil.



The pencil is an example of what three-dimensional shape?
How can the word *parallel* be used to describe features of the pencil?
How can the word *perpendicular* be used to describe features of the pencil?

G.R.1b

Using a dynamic geometry system draw $\triangle ABC$ similar to the one below. Measure the three interior angles. Drag a vertex and make a conjecture about the sum of the interior angles of a triangle. Extend this investigation by overlaying a line on side \overline{AC} . Measure the exterior angle at C and the sum of the interior angles at A and B. Make a conjecture about this sum. Justify your conjectures.

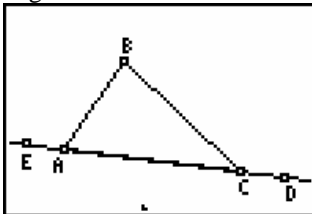

G.R.2 Recognize, compare, and use an array of representational forms

G.R.2a

Consider the theorem below. Write three separate proofs for the theorem, one using synthetic techniques, one using analytical techniques, and one using transformational techniques. Discuss the strengths and weakness of each of the different approaches.

The diagonals of a parallelogram bisect each other.

G.R.3 Use representation as a tool for exploring and understanding mathematical ideas

G.R.3a

Using a dynamic geometry system draw $\triangle ABC$ similar to the one below. Measure the three interior angles. Drag a vertex and make a conjecture about the sum of the interior angles of a triangle. Extend this investigation by overlaying a line on side \overline{AC} . Measure the exterior angle at C and the sum of the interior angles at A and B. Make a conjecture about this sum. Justify your conjectures.

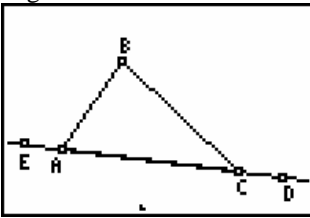

G.R.3b

Investigate the two drawings below using dynamic geometry software. List as many conjectures as you can for each drawing.

G.R.3c

Graph $\triangle ABC$ where $A(-2, -1)$, $B(1, 3)$, and $C(4, -3)$.

Show that $D(2, 1)$ is a point on \overline{BC} .

Show that \overline{AD} is perpendicular to segment \overline{BC} . How is \overline{AD} related to $\triangle ABC$?

Find the area of $\triangle ABC$.

Sketch the image of $\triangle ABC$ under a reflection over the line $y = x$.

Find the area of the image triangle.

Sketch the image of $\triangle ABC$ under a translation, $T_{-3,4}$. Find the area of the image triangle.

Students will select, apply, and translate among mathematical representations to solve problems.

G.R.4 Select appropriate representations to solve problem situations

G.R.4a

Explain how each of the following representations could be used to determine the solution to the following problem situation: A rectangular field is to be enclosed with 100 feet of fence. What dimensions will enclose the field of largest area?

Width	Length	Area
0	50	0
5	45	225
10	40	400
15	35	525
20	30	600
25	25	625
30	20	600
35	15	525
40	10	400
45	5	225
50	0	0

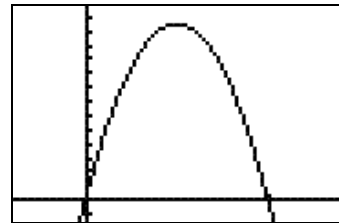
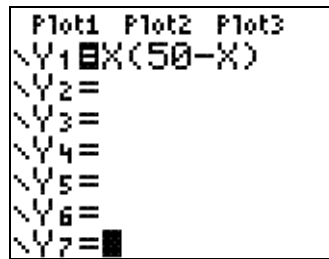

G.R.5 Investigate relationships between different representations and their impact on a given problem

G.R.5 Investigate relationships between different representations and their impact on a given problem

G.R.5a

Using a dynamic geometry system draw $\triangle ABC$ similar to the one shown at the right. Measure the three interior angles. Drag a vertex and make a conjecture about the sum of the interior angles of a triangle.

Extend this investigation by overlaying a line on side \overline{AC} . Measure the exterior angle at C and the sum of the interior angles at A and B. Make a conjecture about this sum. Justify each of your conjectures.

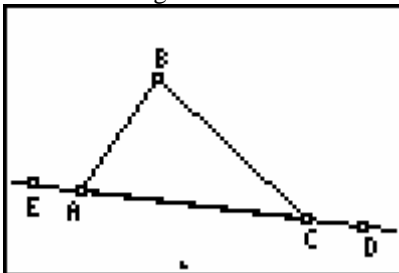

G.R.5b

Explain how each of the following representations could be used to determine the solution to the following problem situation: A rectangular field is to be enclosed with 100 feet of fence. What dimensions will enclose the field of largest area?

Width	Length	Area
0	50	0
5	45	225
10	40	400
15	35	525
20	30	600
25	25	625
30	20	600
35	15	525
40	10	400
45	5	225
50	0	0

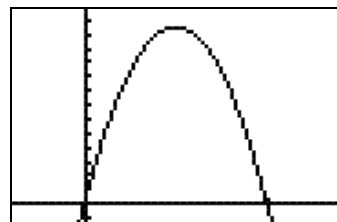
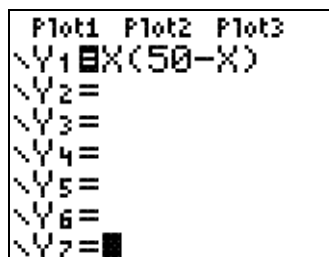

Students will use representations to model and interpret physical, social, and mathematical phenomena.

G.R.6 Use mathematics to show and understand physical phenomena (e.g., determine the number of gallons of water in a fish tank)

G.R.6a

The map below shows a section of North Dakota. The cities of Hazen and Beulah are 19 miles apart and Hazen and Bismarck are 57 miles apart. What are the possible distances from Beulah to Bismarck?



G.R.6b

Point A, B, and C represent three cities. A regional transportation center is to be located so that distance to each city is the same. Where should the transportation center be located? Explain your answer.

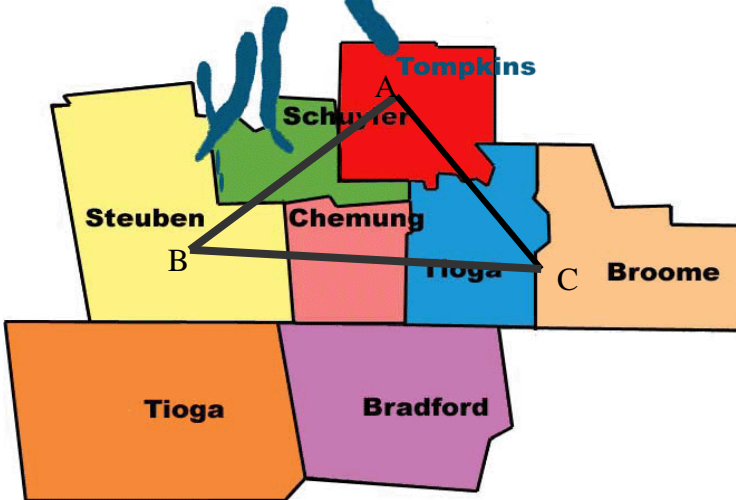

G.R.6 Use mathematics to show and understand physical phenomena (e.g., determine the number of gallons of water in a fish tank)

G.R.6c

The figure below shows the layout of a soccer field. Describe its symmetry. Why do you think this field has this type of symmetry?

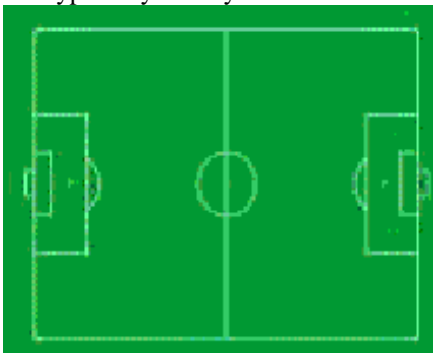

G.R.7 Use mathematics to show and understand social phenomena (e.g., determine if conclusions from another person’s argument have a logical foundation)

G.R.7a

Melvin claims that two lines in space that do not intersect must always be parallel. To support his conjecture he refers to the line of intersection of a wall and the ceiling and the line of intersection of the same wall and the floor. Discuss the validity of his conjecture and his justification.

G.R.8 Use mathematics to show and understand mathematical phenomena (e.g., use investigation, discovery, conjecture, reasoning, arguments, justification and proofs to validate that the two base angles of an isosceles triangle are congruent)

G.R.8a

Justify the fact that if one edge of a triangular prism is perpendicular to its base then the prism is a right triangular prism.

G.R.8b

With a partner construct an angle of 30° . Justify your construction.

[Back to top](#)

Algebra

Note: The algebraic skills and concepts within the Algebra process and content performance indicators must be maintained and applied as students are asked to investigate, make conjectures, give rationale, and justify or prove geometric concepts.

[Back to top](#)

Geometry

Students will use visualization and spatial reasoning to analyze characteristics and properties of geometric shapes.

Geometric Relationships

Note: Two-dimensional geometric relationships are addressed in the Informal and Formal Proofs band.

G.G.1 Know and apply that if a line is perpendicular to each of two intersecting lines at their point of intersection, then the line is perpendicular to the plane determined by them.

G.G.1a

Jim is a carpenter and would like to install a flagpole in his front yard. Carpenters use a tool called a level, shown in the figure below, to determine if objects are level (horizontal) or plumb (vertical). Describe how Jim can use a level to ensure that the flagpole appears vertical from any direction.



G.G.1b

Study the drawing below of a pyramid whose base is quadrilateral $ABCD$. John claims that line segment \overline{EF} is the altitude of the pyramid. Explain what John must do to prove that he is correct.

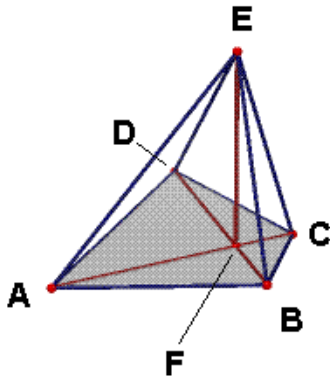

G.G.2 Know and apply that through a given point there passes one and only one plane perpendicular to a given line

G.G.2a

Examine the diagram of a pencil below:



Explain how the pencil illustrates the fact that if two lines are perpendicular to the same line, then they must be parallel.

Explain how the pencil illustrates the fact that if two lines are parallel and the first line is perpendicular to a third line, then the second line must be perpendicular to the third line.

G.G.3 Know and apply that through a given point there passes one and only one line perpendicular to a given plane

G.G.3a

Examine the diagram of a right triangular prism.

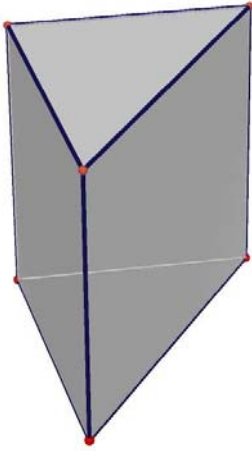

Describe how a plane and the prism could intersect so that the intersection is:

- a line parallel to one of the triangular bases
- a line perpendicular to the triangular bases
- a triangle
- a rectangle
- a trapezoid

G.G.4 Know and apply that two lines perpendicular to the same plane are coplanar

G.G.4a

The figure below is a right hexagonal prism.

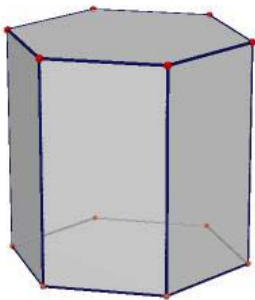

On a copy of the figure sketch a symmetry plane. Then write a description of the symmetry plane that uses the word *parallel*.

On a copy of the figure sketch another symmetry plane. Then write a description that uses the word *perpendicular*.

G.G.4b The figure below in three dimensional space, where \overline{AB} is perpendicular to \overline{BC} and \overline{DC} is perpendicular to \overline{BC} , illustrates that two lines perpendicular to the same line are not necessarily parallel. Must two lines perpendicular to the same plane be parallel? Discuss this problem with a partner.

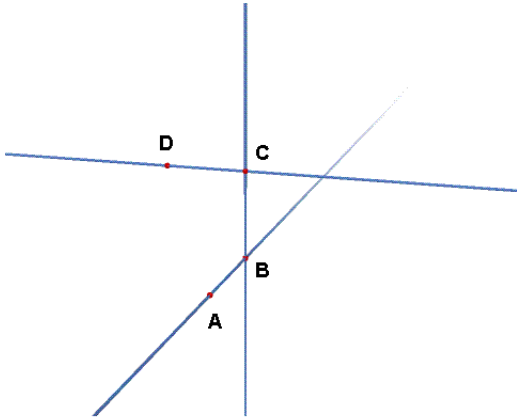

G.G.5 Know and apply that two planes are perpendicular to each other if and only if one plane contains a line perpendicular to the second plane

G.G.5a

Julie wishes to construct a wall in the basement of her apartment. Describe what she must do to ensure that the wall is perpendicular to the floor of the basement. Explain why Julie's procedure will work, using appropriate mathematical terminology.

G.G.6 Know and apply that if a line is perpendicular to a plane, then any line perpendicular to the given line at its point of intersection with the given plane is in the given plane

G.G.6a

Justify the fact that if one edge of a triangular prism is perpendicular to its base then the prism is a right triangular prism.

G.G.7 Know and apply that if a line is perpendicular to a plane, then every plane containing the line is perpendicular to the given plane

G.G.7a

Examine the four figures below:

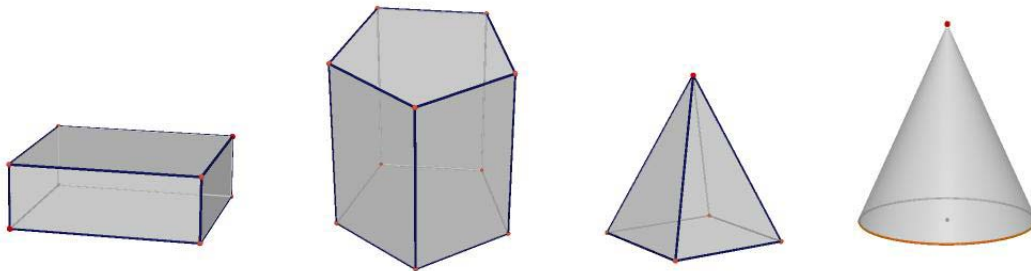

Each figure has how many symmetry planes?
Describe the location of all the symmetry planes for each figure.

G.G.8 Know and apply that if a plane intersects two parallel planes, then the intersection is two parallel lines

G.G.8a

The figure below is a right hexagonal prism.

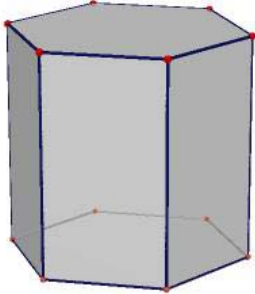

On a copy of the figure sketch a symmetry plane. Then write a description that uses the word *parallel*.

On a copy of the figure sketch another symmetry plane. Then write a description that uses the word *perpendicular*.

G.G.9 Know and apply that if two planes are perpendicular to the same line, they are parallel

G.G.9a

The figure below shows a right hexagonal prism.

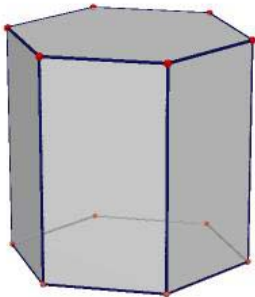

A plane that intersects a three-dimensional figure such that one half is the reflected image of the other half is called a *symmetry plane*. On a copy of the figure sketch a symmetry plane. Then write a description of the symmetry plane that uses the word *parallel*.

On a copy of the figure sketch another symmetry plane. Then write a description that uses the word *perpendicular*.

G.G.9b

Draw a line on a piece of cardboard. Use additional pieces of cardboard to construct two planes that are perpendicular to the line that you drew. Make a conjecture regarding those two planes and justify your conjecture.

G.G.10 Know and apply that the lateral edges of a prism are congruent and parallel

G.G.10a

Examine the diagram of a pencil below:



The pencil is an example of what three-dimensional shape?

How can the word *parallel* be used to describe features of the pencil?

How can the word *perpendicular* be used to describe features of the pencil?

G.G.11 Know and apply that two prisms have equal volumes if their bases have equal areas and their altitudes are equal

G.G.11a

Examine the prisms below. Calculate the volume of each of the prisms. Observe your results and make a mathematical conjecture. Share your conjecture with several other students and formulate a conjecture that the entire group can agree on. Write a paragraph that proves your conjecture.

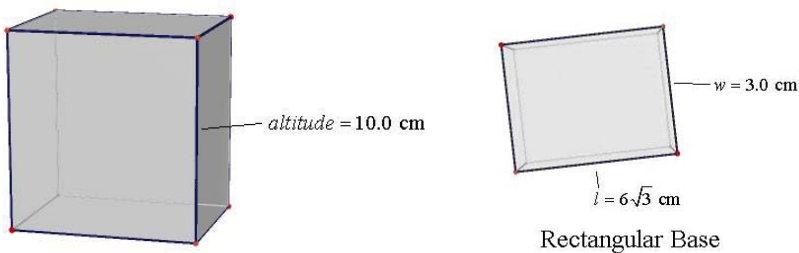
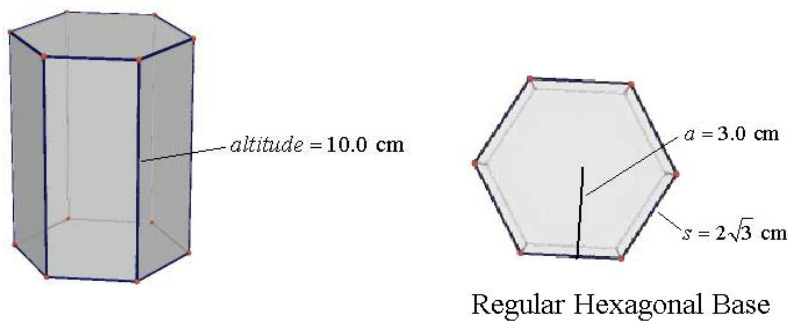
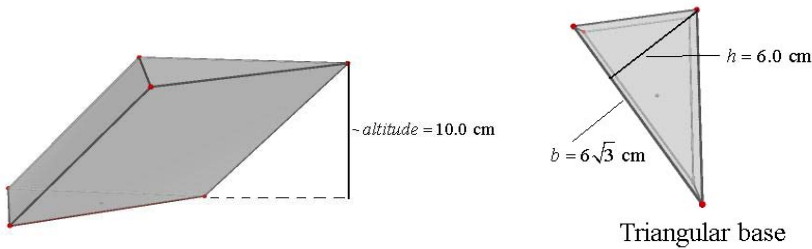

G.G.11b

A rectangular gift box with whole number dimensions has a volume of 36 cubic inches.

Find the dimensions of all possible boxes. Determine the box that would require the least amount of wrapping paper to cover the box.

Find the dimensions of all possible boxes if the volume is 30 cubic inches. Determine the box that would require the least amount of wrapping paper to cover the box.

Write a conjecture about the dimensions of a rectangular box with any fixed volume that would require the least amount of wrapping paper to cover the box. Write a mathematical argument for why your conjecture is true.

G.G.12 Know and apply that the volume of a prism is the product of the area of the base and the altitude

G.G.12a

A rectangular gift box with whole number dimensions has a volume of 36 cubic inches.

Find the dimensions of all possible boxes. Determine the box that would require the least amount of wrapping paper to cover the box.

Find the dimensions of all possible boxes if the volume is 30 cubic inches. Determine the box that would require the least amount of wrapping paper to cover the box.

Write a conjecture about the dimensions of a rectangular box with any fixed volume that would require the least amount of wrapping paper to cover the box. Write a mathematical argument for why your conjecture is true.

G.G.12b

Analyze the following changes in dimensions of three-dimensional figures to predict the changes in the corresponding volumes:

One soup can has dimensions that are twice those of a smaller can.

One box of pasta has dimensions that are three times the dimensions of a smaller box.

The dimensions of one cone are five times the dimensions of another cone.

The dimensions of one triangular prism are x times the dimensions of another triangular prism.

G.G.12c

A swimming pool in the shape of a rectangular prism has dimensions 26 feet long, 16 feet wide, and 6 feet deep.

How much water is needed to fill the pool to 6 inches from the top?

How many gallons of paint are needed to paint the inside of the pool if one gallon of paint covers approximately 60 square feet?

How much material is needed to make a pool cover that extends 1.5 feet beyond the pool on all sides?

How many 6 inch square tiles are needed to tile the top of the inside faces of the pool?

G.G.12d

Students in one mathematics class noticed that a local movie theater sold popcorn in different shapes of containers, for different prices. They wondered which of the choices was the best buy. Analyze the three popcorn containers below. Which is the best buy? Explain.

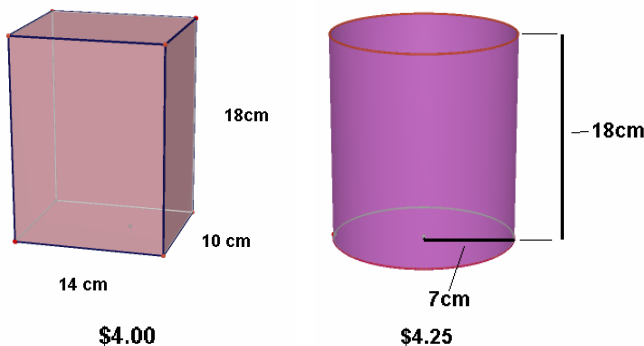

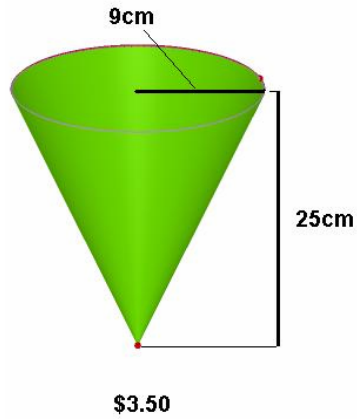

G.G.13 Apply the properties of a regular pyramid, including:
 lateral edges are congruent
 lateral faces are congruent isosceles triangles
 volume of a pyramid equals one-third the product of the area of the base and the altitude

G.G.13a

The Great Pyramid of Giza is a right pyramid with a square base. The measurements of the Great Pyramid include a base, b , equal to approximately 230 meters and a slant height, s , equal to approximately 464 meters.

Calculate the height of the Great Pyramid to the nearest meter.

Calculate the area of the base of the Great Pyramid.

Calculate the volume of the Great Pyramid.

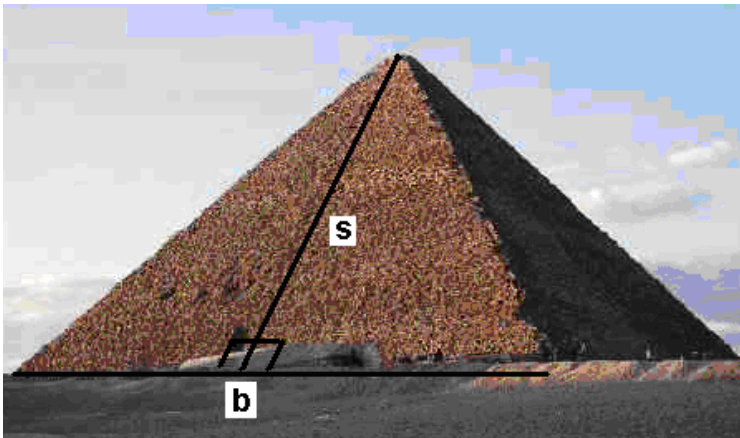

G.G.14 Apply the properties of a cylinder, including:
bases are congruent
volume equals the product of the area of the base and the altitude
lateral area of a right circular cylinder equals the product of an altitude and the circumference of the base

G.G.14a

A manufacturing company is charged with designing a can that is to be constructed in the shape of a right circular cylinder. The only requirements are that the can must be airtight, hold at least 23 cubic inches and should require as little material as possible to construct. Each of the following cans was submitted for consideration by the engineering department.

Which can would you choose to produce?
Justify your choice.

Proposal #1

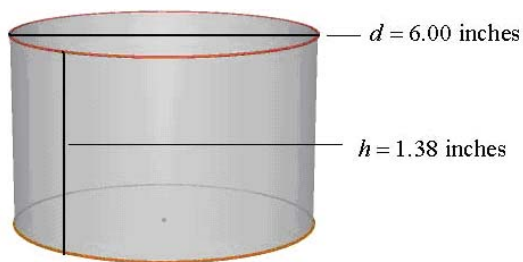

Proposal #2

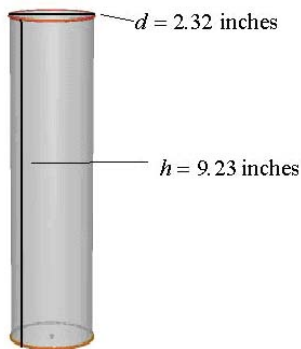

Proposal #3

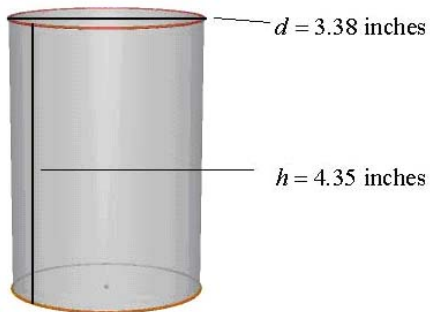

G.G.14b

What changes the volume of a cylinder more, doubling the diameter or doubling the height? Provide evidence for your conjecture. Then write a mathematical argument for why your conjecture is true.

G.G.14c

Analyze the following changes in dimensions of three-dimensional figures to predict the change in the corresponding volumes:

- One soup can has dimensions that are twice those of a smaller can.
- One box of pasta has dimensions that are three times the dimensions of a smaller box.
- The dimensions of one cone are five times the dimensions of another cone.
- The dimensions of one triangular prism are x times the dimensions of another triangular prism.

G.G.14d

Consider a cylinder, a cone, and a sphere that have the same radius and the same height.

Sketch and label each figure.

What is the relationship between the volume of the cylinder and the volume of the cone?

What is the relationship between the volume of the cone and the volume of the sphere?

What is the relationship between the volume of the cylinder and the volume of the sphere?

Use the formulas for the volume of a cylinder, a cone, and a sphere to justify mathematically that the relationships are correct.

G.G.14e

Students in one mathematics class noticed that a local movie theater sold popcorn in different shapes of containers, for different prices. They wondered which of the choices was the best buy. Analyze the three popcorn containers below. Which is the best buy? Explain.

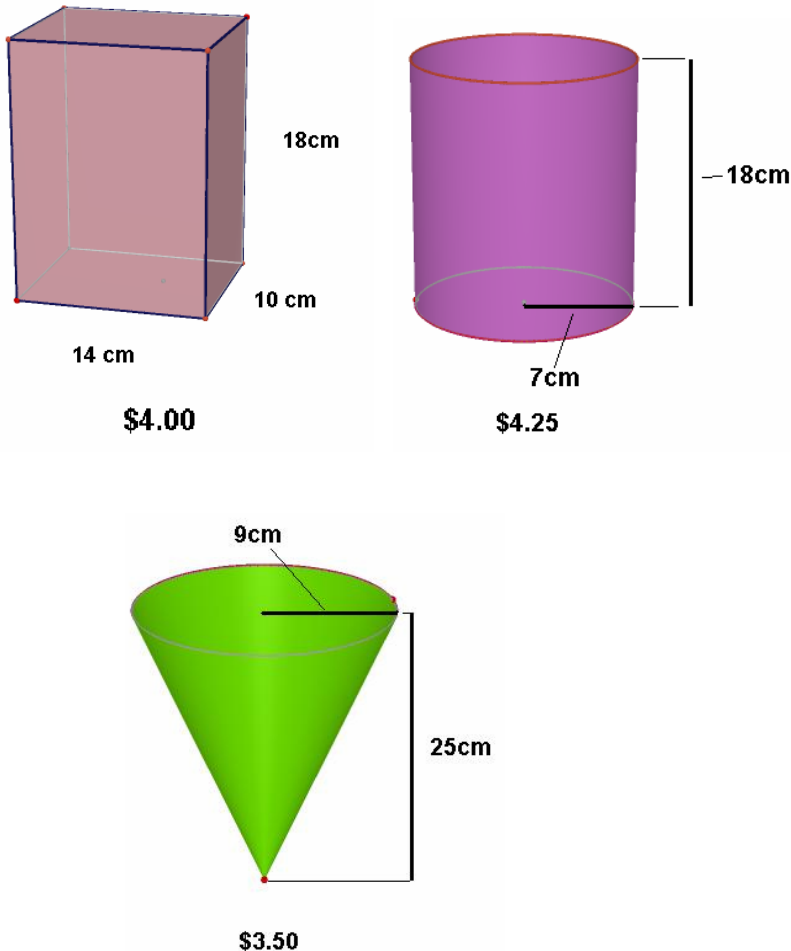

**G.G.15 Apply the properties of a right circular cone, including:
lateral area equals one-half the product of the slant height and the
circumference of its base volume is one-third the product of the area of its
base and its altitude**

G.G.15a

Obtain several different size cylinders made of metal or cardboard. Using stiff paper, construct a cone with the same base and height as each cylinder. Fill the cone with rice, then pour the rice into the cylinder. Repeat until the cylinder is filled. Record your data.

What is the relationship between the volume of the cylinder and the volume of the corresponding cone?

Collect the class data for this experiment.

Use the data to write a formula for the volume of a cone with radius r and height h .

G.G.15b

Analyze the following changes in dimensions of three-dimensional figures to predict the change in the corresponding volumes:

One soup can has dimensions that are twice those of a smaller can.

One box of pasta has dimensions that are three times the dimensions of a smaller box.

The dimensions of one cone are five times the dimensions of another cone.

The dimensions of one triangular prism are x times the dimensions of another triangular prism.

G.G.15c

Consider a cylinder, a cone, and a sphere that have the same radius and the same height.

Sketch and label each figure.

What is the relationship between the volume of the cylinder and the volume of the cone?

What is the relationship between the volume of the cone and the volume of the sphere?

What is the relationship between the volume of the cylinder and the volume of the sphere?

Use the formulas for the volume of a cylinder, a cone, and a sphere to justify mathematically that the relationships are correct.

G.G.15d

Students in one mathematics class noticed that a local movie theater sold popcorn in different shapes of containers, for different prices. They wondered which of the choices was the best buy. Analyze the three popcorn containers below. Which is the best buy? Explain.

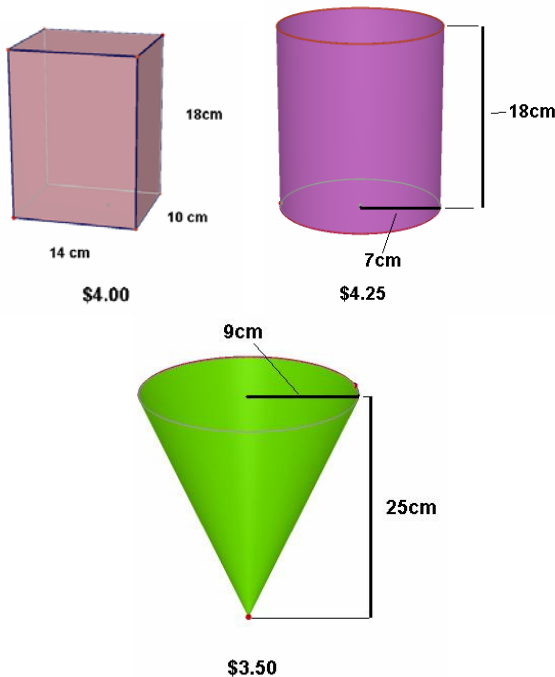

- G.G.16 Apply the properties of a sphere, including:**
the intersection of a plane and a sphere is a circle
a great circle is the largest circle that can be drawn on a sphere
two planes equidistant from the center of the sphere and intersecting the sphere do so in congruent circles
surface area is $4\pi r^2$
volume is $\frac{4}{3}\pi r^3$

G.G.16a

Consider a cylinder, a cone, and a sphere that have the same radius and the same height.

Sketch and label each figure.

What is the relationship between the volume of the cylinder and the volume of the cone?

What is the relationship between the volume of the cone and the volume of the sphere?

What is the relationship between the volume of the cylinder and the volume of the sphere?

Use the formulas for the volume of a cylinder, a cone, and a sphere to justify mathematically that the relationships are correct.

G.G.16b

Navigators have historically used lines of latitude and lines of longitude to describe their position on the surface of the earth. Are any of the lines of latitude great circles? Explain your answer. Are any of the lines of longitude great circles? Explain your answer.

Constructions

- G.G.17 Construct a bisector of a given angle, using a straightedge and compass, and justify the construction**

G.G.17a

Use a straightedge to draw an angle and label it $\angle ABC$. Then construct the bisector of $\angle ABC$ by following the procedure outlined below:

Step 1: With the compass point at B , draw an arc that intersects \overrightarrow{BA} and \overrightarrow{BC} . Label the intersection points D and E respectively.

Step 2: With the compass point at D and then at E , draw two arcs with the same radius that intersect in the interior of $\angle ABC$. Label the intersection point F .

Step 3: Draw ray \overrightarrow{BF} .

Write a proof that ray \overrightarrow{BF} bisects $\angle ABC$.

- G.G.18 Construct the perpendicular bisector of a given segment, using a straightedge and compass, and justify the construction**

G.G.18a

Use a straightedge to draw a segment and label it AB . Then construct the perpendicular bisector of segment AB by following the procedure outlined below.

Step 1: With the compass point at A , draw a large arc with a radius greater than $\frac{1}{2}AB$ but less than the length of AB so that the arc intersects \overline{AB} .

Step 2: With the compass point at B , draw a large arc with the same radius as in step 1 so that the arc intersects the arc drawn in step 1 twice, once above \overline{AB} and once below \overline{AB} . Label the intersections of the two arcs C and D .

Step 3: Draw segment CD .

Write a proof that segment CD is the perpendicular bisector of segment AB .

G.G.19 Construct lines parallel (or perpendicular) to a given line through a given point, using a straightedge and compass, and justify the construction

G.G.19a

Given segments of length a and b , construct a rectangle that has a vertex at A in the line below. Justify your work.

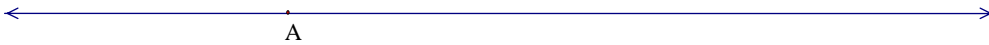
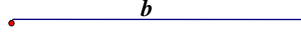
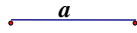

G.G.19b

Given the following figure, construct a parallelogram having sides \overline{AB} and \overline{BC} and $\angle ABC$. Explain your construction.

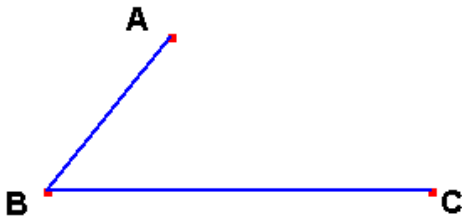

G.G.20 Construct an equilateral triangle, using a straightedge and compass, and justify the construction

G.G.20a

Construct an equilateral triangle with sides of length b and justify your work.

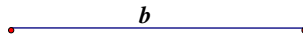

G.G.20b Clare states that the blue and green triangles constructed using only a compass and straight edge are equilateral in the diagram below. Explain why you agree or disagree with Clare.

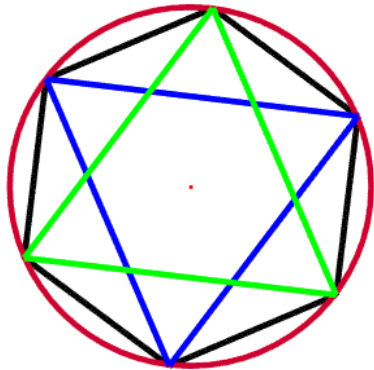

Locus

G.G.21 Investigate and apply the concurrence of medians, altitudes, angle bisectors, and perpendicular bisectors of triangles

G.G.21a

Using dynamic geometry software locate the circumcenter, incenter, orthocenter, and centroid of a given triangle. Use your sketch to answer the following questions:

Do any of the four centers always remain inside the circle?

If a center is moved outside the triangle, under what circumstances will it happen?

Are the four centers ever collinear? If so, under what circumstances?

Describe what happens to the centers if the triangle is a right triangle.

G.G. 21b

Four of the centers of a triangle are the orthocenter, incenter, circumcenter, and centroid. Which of these four centers are always on or inside the triangle? Justify your answer.

G.G.22 Solve problems using compound loci

G.G.22a

Determine the number of points that are two units from the y -axis and four units from the point $(3,1)$.

G.G.22b

Write an equation of the locus of points equidistant from the set of points that are six units from the origin, and the set of points that are two units from the origin.

G.G.23 Graph and solve compound loci in the coordinate plane

G.G.23a

Determine the point(s) in the plane that are equidistant from the points $A(2,6)$, $B(4,4)$, and $C(8,6)$.

G.G.23b

Find the locus of points that satisfy the following conditions: equidistant from the lines $2y - x = 3$ and $x - 2y = 5$ and at a distance of 2 from the point $(7,3)$.

Students will identify and justify geometric relationships formally and informally.

Informal and Formal Proofs

G.G.24 Determine the negation of a statement and establish its truth value

G.G.24a

Given the following statement, determine the truth value of the statement, write the negation of the statement and determine the truth value of the negation.

The diagonals of a rectangle are congruent.

G.G.24b

Write the negation of the following statement. Determine the truth value of both the statement and its negation.

If a triangle is isosceles then its base angles are congruent.

G.G.24c

Write the negation of the following statement. Determine the truth value of both the statement and its negation.

All squares are rectangles.

G.G.25 Know and apply the conditions under which a compound statement (conjunction, disjunction, conditional, biconditional) is true

G.G.25a

A computer reports a value of 0 for a false expression and a 1 for a true expression. What value will be reported for the expression shown in the accompanying figure?

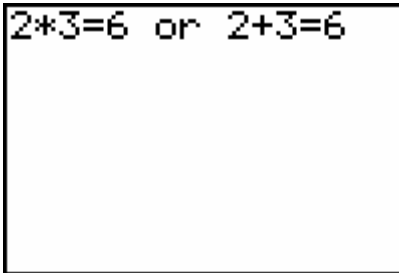

G.G.25b

Using the definitions of regular polygon and of pentagon and the properties of logic, determine which of the following polygons is a regular pentagon. Justify your answer to a partner.

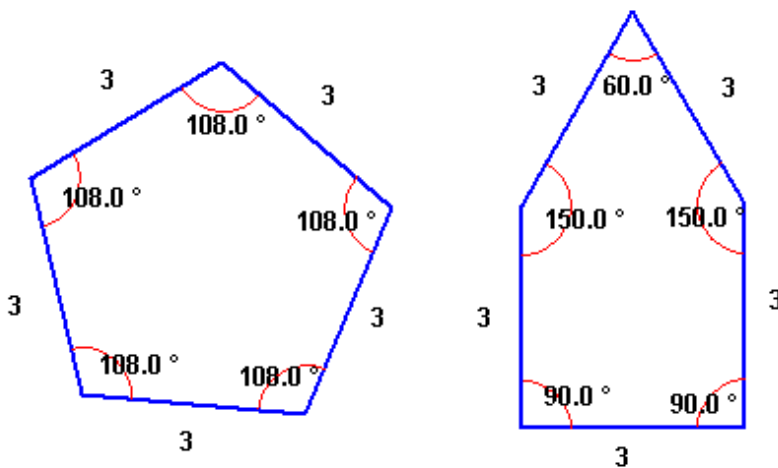

G.G.26 Identify and write the inverse, converse, and contrapositive of a given conditional statement and note the logical equivalences

G.G.26a

Write the inverse, converse, and contrapositive of the following statement and identify which of these statements are logically equivalent.

If a quadrilateral is a rectangle then its diagonals are congruent.

G.G.27 Write a proof arguing from a given hypothesis to a given conclusion

G.G.27a

Prove that a quadrilateral whose diagonals bisect each other must be a parallelogram.

G.G.27b

Prove that a quadrilateral whose diagonals are perpendicular bisectors of each other must be a rhombus.

G.G.27c

In the accompanying diagram figure $ABCD$ is a parallelogram and \overline{AC} and \overline{BD} are diagonals that intersect at point E . Identify precisely which isometry can be used to map $\triangle AED$ onto $\triangle CEB$. Use the properties of a parallelogram to prove that $\triangle CEB$ is the image of $\triangle AED$ under that isometry.

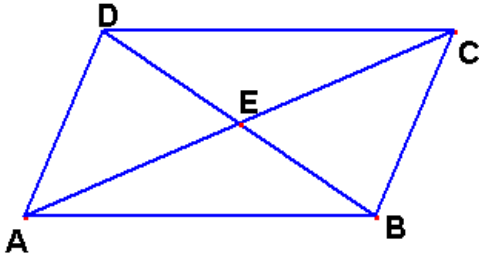

G.G.27d

In the accompanying diagram figure $\triangle RQ'R'$ is the image of $\triangle PQR$ under a translation through vector \overline{PR} . Prove that $\overline{Q'R'}$ is parallel to \overline{QR} .

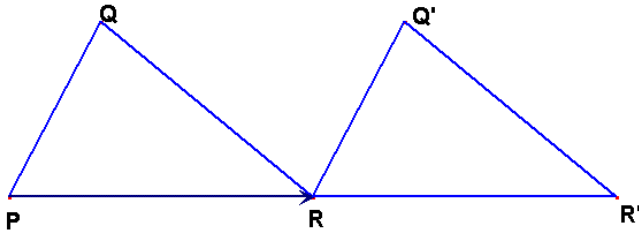

G.G.27e

In the accompanying diagram figure quadrilateral $ABCD$ is a rectangle. Prove that diagonals \overline{AC} and \overline{BD} are congruent.

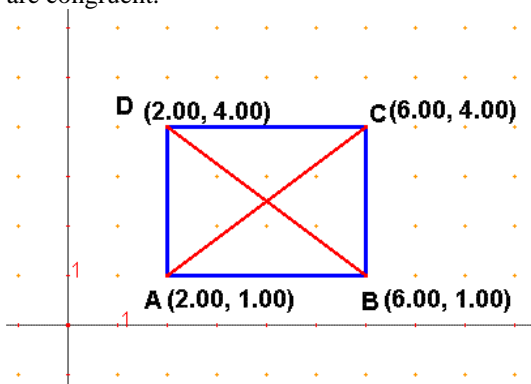

G.G.27f

Consider the theorem below. Write three separate proofs for the theorem, one using synthetic techniques, one using analytical techniques, and one using transformational techniques. Discuss the strengths and weakness of each of the different approaches.

The diagonals of a parallelogram bisect each other.

G.G.28 Determine the congruence of two triangles by using one of the five congruence techniques (SSS, SAS, ASA, AAS, HL), given sufficient information about the sides and/or angles of two congruent triangles

G.G.28a

The following procedure describes how to construct ray \overrightarrow{BF} which bisects $\angle ABC$. After performing the construction, use a pair of congruent triangles to prove that ray \overrightarrow{BF} bisects $\angle ABC$.

Step 1: With the compass point at B , draw an arc that intersects \overline{BA} and \overline{BC} . Label the intersection points D and E respectively.

Step 2: With the compass point at D and then at E , draw two arcs with the same radius that intersect in the interior of $\angle ABC$. Label the intersection point F .

Step 3: Draw ray \overrightarrow{BF} .

G.G.28b

The following procedure describes how to construct line \overleftrightarrow{CD} which is the perpendicular bisector of segment \overline{AB} . After performing the construction, use a pair of congruent triangles to prove that line \overleftrightarrow{CD} is the perpendicular bisector of segment \overline{AB} .

Step 1: With the compass point at A , draw a large arc with a radius greater than $\frac{1}{2}AB$ but less than the length of AB so that the arc intersects \overline{AB} .

Step 2: With the compass point at B , draw a large arc with the same radius as in step 1 so that the arc intersects the arc drawn in step 1 twice, once above \overline{AB} and once below \overline{AB} . Label the intersections of the two arcs C and D .

Step 3: Draw line \overleftrightarrow{CD} .

G.G.29 Identify corresponding parts of congruent triangles

G.G.29a

In the accompanying figure $\triangle AGE \cong \triangle WIZ$.

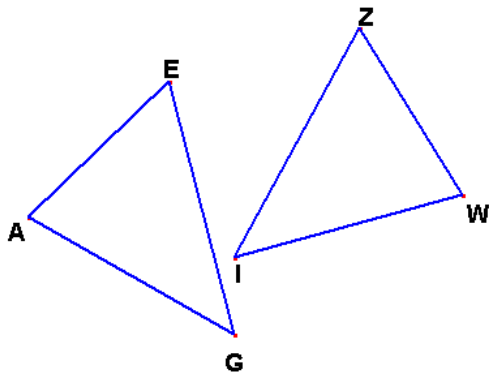

Which sides of $\triangle AGE$ must be congruent to which sides of $\triangle WIZ$? Which angles of $\triangle AGE$ must be congruent to which angles $\triangle WIZ$?

G.G.29b

If $\triangle ABC \cong \triangle DEF$ and \overline{AC} is the longest side of $\triangle ABC$, what is the longest side of $\triangle DEF$?

G.G.30 Investigate, justify, and apply theorems about the sum of the measures of the angles of a triangle

G.G.30a

Using dynamic geometry software draw $\triangle ABC$ similar to the one in the figure below. Measure the three interior angles. Drag a vertex and make a conjecture about the sum of the interior angles of a triangle.

Extend this investigation by overlaying a line on side \overline{AC} . Measure the exterior angle at C and the sum of the interior angles at A and B. Make a conjecture about this sum. Justify your conjectures.

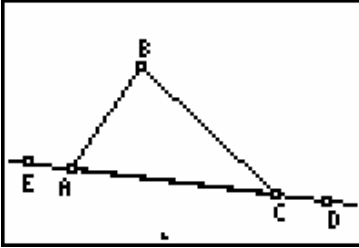

G.G.31 Investigate, justify, and apply the isosceles triangle theorem and its converse

G.G.31a

Prove: The bisector of the vertex angle of an isosceles triangle is perpendicular to the base.

G.G.32 Investigate, justify, and apply theorems about geometric inequalities, using the exterior angle theorem

G.G.32a

State the exterior angle theorem in two different ways. Use inequality in one statement of the theorem and equality in the other. Discuss why the adoption of one of these statements might be more appropriate than another.

G.G.32b

Use the information given in the diagram to determine the measure of $\angle ACB$.

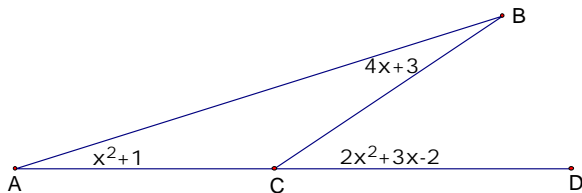

G.G.33 Investigate, justify, and apply the triangle inequality theorem

G.G.33a

The map below shows a section of North Dakota. The cities of Hazen and Beulah are 19 miles apart and Hazen and Bismarck are 57 miles apart. What are the possible distances from Beulah to Bismarck?



G.G.34 Determine either the longest side of a triangle given the three angle measures or the largest angle given the lengths of three sides of a triangle

G.G.34a

The figure below shows rectangle ABCD with triangle BEC. If $DC = 2AD$, $BE = AB$, and $CE > CD$, determine the largest angle of triangle BEC.

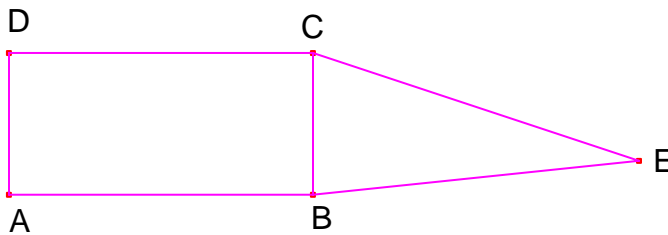

G.G.35 Determine if two lines cut by a transversal are parallel, based on the measure of given pairs of angles formed by the transversal and the lines

G.G.35a

Investigate the two drawings using dynamic geometry software. Write as many conjectures as you can for each drawing.

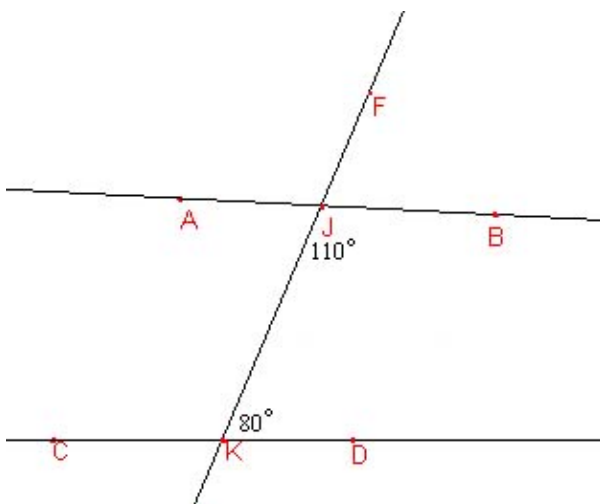

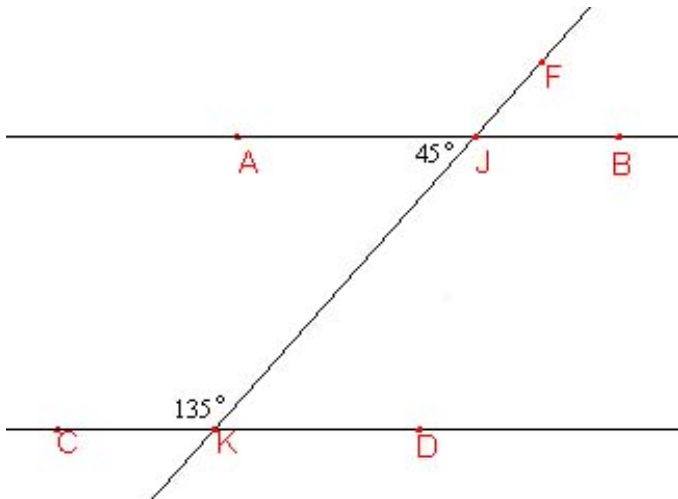

G.G.35b

In the following figure, certain angle measures are given. Use the information provided to show that \overline{AB} is parallel to \overline{CD} and that \overline{EF} is not parallel to \overline{CD} .

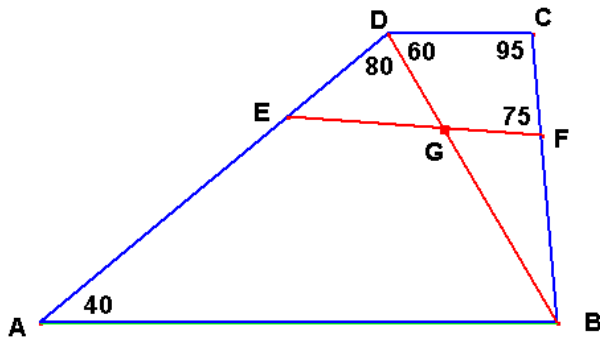

G.G.36 Investigate, justify, and apply theorems about the sum of the measures of the interior and exterior angles of polygons

G.G.36a

A polygon has eleven sides. What is the sum of the interior angles of the polygon? Justify your answer.

GG.36b

Explain how the following sequence of diagrams could constitute a “Proof Without Words” (one that is based on visual elements, without any comments) for the theorem: The sum of the exterior angles of a polygon is 360 degrees.

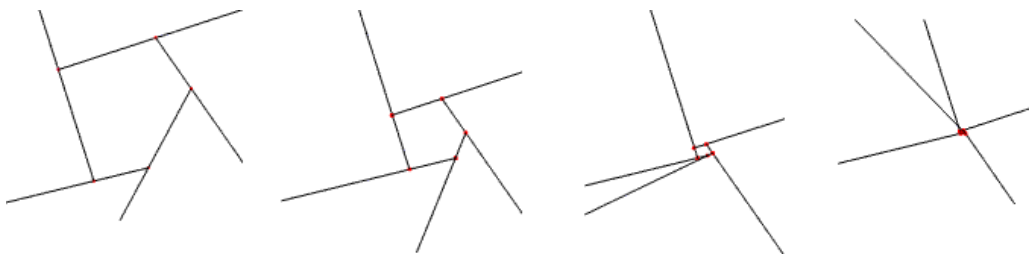

G.G.37 Investigate, justify, and apply theorems about each interior and exterior angle measure of regular polygons

G.G.37a

Use a compass or dynamic geometry software to construct or draw a **regular** dodecagon (a regular 12-sided polygon).

What is the measure of each central angle in the regular dodecagon?

Find the measure of each angle of the regular dodecagon.

Extend one of the sides of the regular dodecagon.

What is the measure of the exterior angle that is formed when one of the sides is extended?

G.G.37b

Find the number of sides of a regular n -gon that has an exterior angle whose measure is 10° .

G.G.37c

Jeanette invented the rule $A = \frac{(n-2)180}{n}$ to find the measure of A of one angle in a regular n -gon. Do you

think that Jeannette's rule is correct? Justify your reasoning.

Use the rule to predict the measure of one angle of a regular 20-gon. As the number of sides of a regular polygon increases, how does the measure of one of its angles change? When will the measure of each angle of a regular polygon be a whole number?

G.G.37d

The following graphic is a stop sign.

test



regular octagon

What is the sum of the measures of the angles of a *stop* sign?

What is the measure of each of the angles of a *stop* sign?

What is the measure of an exterior angle of a *stop* sign?

Describe all the symmetries of a *stop* sign.

G.G.38 Investigate, justify, and apply theorems about parallelograms involving their angles, sides, and diagonals

G.G.38a

Use dynamic geometry to **construct** a parallelogram. Investigate this construction and write conjectures concerning the angles, sides, and diagonals of a parallelogram.

G.G.38b

In the accompanying diagram figure $ABCD$ is a parallelogram and \overline{AC} and \overline{BD} are diagonals that intersect at point E . Determine at least two pairs of triangles that are congruent and state which properties of a parallelogram are necessary to prove that the triangles are congruent.

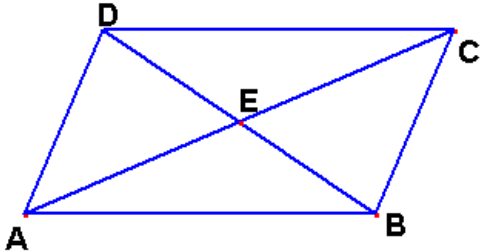

G.G.38c

Examine the diagonals of each type of quadrilateral (parallelogram, rhombus, square, rectangle, kite, trapezoid, and isosceles trapezoid).

For which of these quadrilaterals are the diagonals also lines of symmetry?

For the quadrilaterals whose diagonals are lines of symmetry, identify other properties that are a direct result of the symmetry.

Which quadrilaterals have congruent diagonals?

Are the diagonals in these quadrilaterals also lines of symmetry?

G.G.39 Investigate, justify, and apply theorems about special parallelograms (rectangles, rhombuses, squares) involving their angles, sides, and diagonals

G.G.39a

Examine the diagonals of each type of quadrilateral (rhombus, square, rectangle).

For which of these quadrilaterals are the diagonals also lines of symmetry?

For the quadrilaterals whose diagonals are lines of symmetry, identify other properties that are a direct result of the symmetry

Which quadrilaterals have congruent diagonals?

Are the diagonals in these quadrilaterals also lines of symmetry?

G.G.39b

In the following figure quadrilateral $ABCD$ is a rectangle. Find the area of $\triangle BCE$.

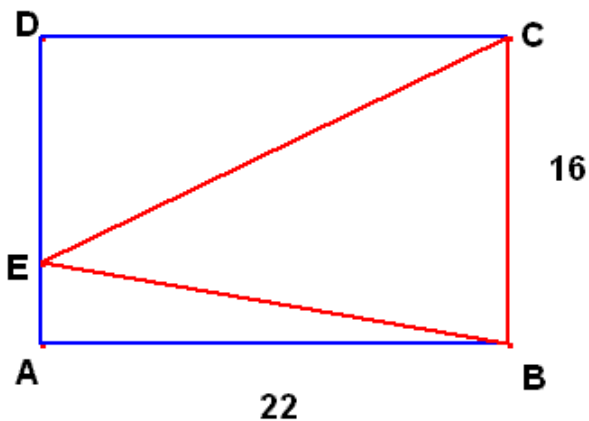

G.G.40 Investigate, justify, and apply theorems about trapezoids (including isosceles trapezoids) involving their angles, sides, medians, and diagonals

G.G.40a

In the accompanying figure \overline{MN} is a median of trapezoid $ABCD$. Determine the length of the median.

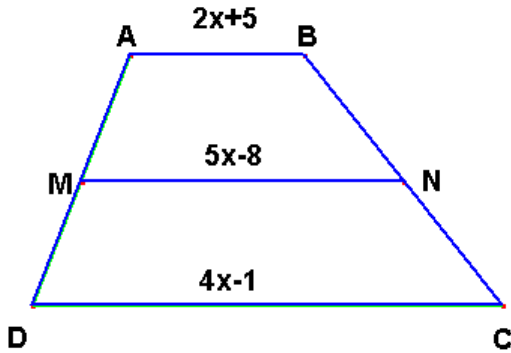

G.G.40b

Prove that the median of a trapezoid is parallel to the bases and equal to one-half their sum.

G.G.40c

In the accompanying diagram figure $PQRS$ is an isosceles trapezoid and \overline{PR} and \overline{QS} are diagonals that intersect at point T . Determine a pair of triangles that are congruent and state which properties of an isosceles trapezoid are necessary to prove that the triangles are congruent.

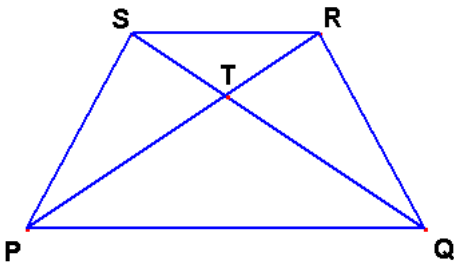

G.G.41 Justify that some quadrilaterals are parallelograms, rhombuses, rectangles, squares, or trapezoids

G.G.41a

In the accompanying figure $m\angle 1 + m\angle 4 = 180^\circ$ and $\overline{DC} \cong \overline{AB}$. Prove that ABCD is a parallelogram.

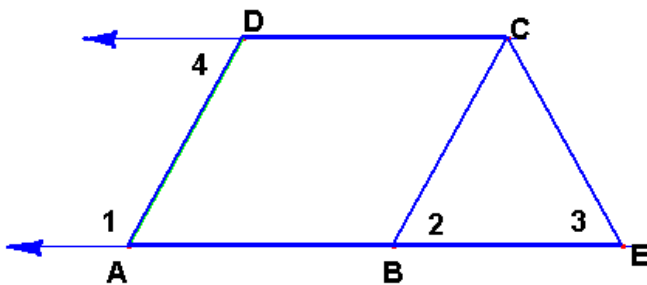

G.G.41b

Prove that a quadrilateral whose diagonals bisect each other must be a parallelogram.

G.G.41c

Prove that a quadrilateral whose diagonals are perpendicular bisectors of each other must be a rhombus.

G.G.42 Investigate, justify, and apply theorems about geometric relationships, based on the properties of the line segment joining the midpoints of two sides of the triangle

G.G.42a

In the drawing at the right D, E, and F are the midpoints of the respective sides \overline{AC} , \overline{AB} , and \overline{CB} of triangle $\triangle ABC$. Point H, I, and J are the midpoints of sides \overline{DE} , \overline{EF} , and \overline{FD} respectively of triangle $\triangle DEF$. Describe the outcome of rotating $\triangle ADE$, $\triangle EFB$, $\triangle DCF$ through an angle of 180° about points H, I, and J.

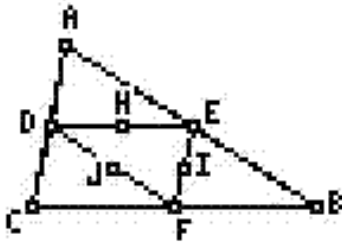

G.G.42b

In the following figure points Q , R , S , and T are the midpoints of the sides of quadrilateral $MNOP$. Prove that quadrilateral $QRST$ is a parallelogram.

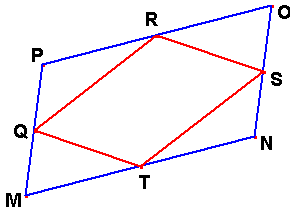

G.G.43 Investigate, justify, and apply theorems about the centroid of a triangle, dividing each median into segments whose lengths are in the ratio 2:1

G.G.43a

The vertices of a triangle ABC are A(4,5), B(6,1), and C(8,9). Determine the coordinates of the centroid of triangle ABC and investigate the lengths of the segments of the medians. Make a conjecture.

G.G.43b

Using dynamic geometry software, construct the following figure in which point C is the *centroid* of

$\triangle PQR$. Show that point P' is the image of point C under a dilation centered at point P with ratio $\frac{3}{2}$

(i.e. $D_{P, \frac{3}{2}}(C) = P'$). Justify mathematically that $\frac{3}{2}$ is the correct ratio for the dilation. In similar fashion

show that $D_{Q, \frac{3}{2}}(C) = Q'$ and $D_{R, \frac{3}{2}}(C) = R'$.

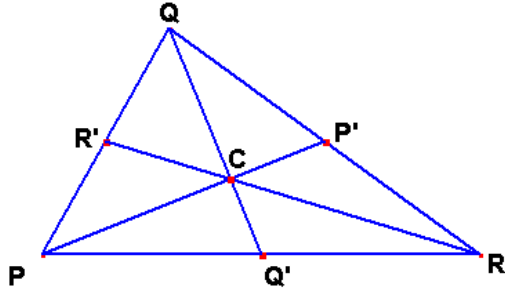

G.G.44 Establish similarity of triangles, using the following theorems: AA, SAS, and SSS

G.G.44a

In the accompanying diagram \overline{PAB} and \overline{PCD} are secants to circle O . Determine two triangles that are similar and prove your conjecture.

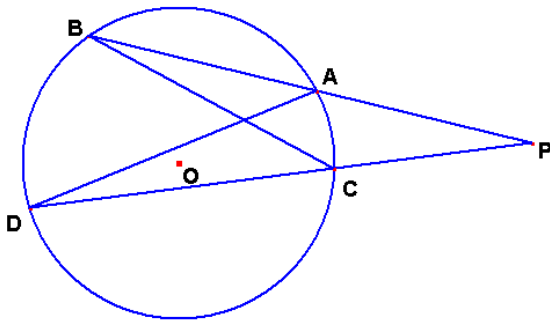

G.G.45 Investigate, justify, and apply theorems about similar triangles

G.G.45a

$\triangle ABC$ is isosceles with $\overline{AB} \cong \overline{AC}$, altitudes \overline{CE} and \overline{AD} are drawn. Prove that $(AC)(EB) = (CB)(DC)$.

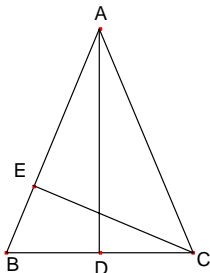

G.G.45b

In the accompanying figure, \overline{AT} is tangent to circle O at point T , and \overline{ADE} is a secant to circle O . Use similar triangles to prove that $(AT)^2 = (AE)(AD)$.

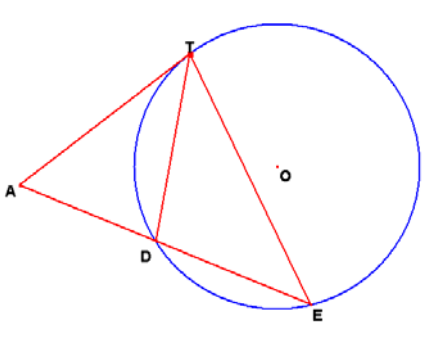

G.G.46 Investigate, justify, and apply theorems about proportional relationships among the segments of the sides of the triangle, given one or more lines parallel to one side of a triangle and intersecting the other two sides of the triangle

G.G.46a

In $\triangle ABC$, \overline{DE} is drawn parallel to \overline{AC} . Model this drawing using dynamic geometry software. Using the measuring tool, determine the lengths AD, DB, CE, EB, DE, and AC. Use these lengths to form ratios and to determine if there is a relationship between any of the ratios. Drag the vertices of the original triangle to see if any of the ratios remain the same. Write a proof to establish your work.

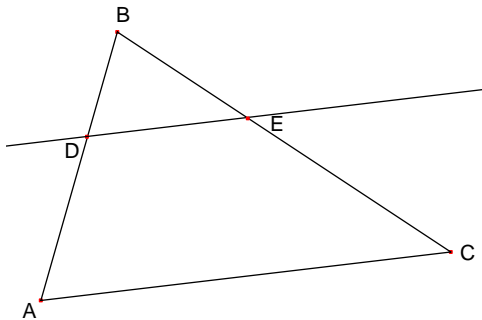

G.G.47 Investigate, justify, and apply theorems about mean proportionality: the altitude to the hypotenuse of a right triangle is the mean proportional between the two segments along the hypotenuse the altitude to the hypotenuse of a right triangle divides the hypotenuse so that either leg of the right triangle is the mean proportional between the hypotenuse and segment of the hypotenuse adjacent to that leg

G.G.47a

In the circle shown in the accompanying diagram, \overline{CB} is a diameter and \overline{AD} is perpendicular to \overline{CB} . Determine the relationship between the measures of the segments shown.

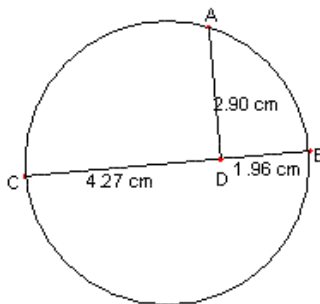

G.G.48 Investigate, justify, and apply the Pythagorean theorem and its converse

G.G.48a

A walkway 30 meters long forms the diagonal of a square playground. To the nearest tenth of a meter, how long is a side of the playground?

G.G.48b

The Great Pyramid of Giza is a right pyramid with a square base. The measurements of the Great Pyramid include a base b equal to approximately 230 meters and a slant height s equal to approximately 464 meters.

Use your knowledge of pyramids to determine the current height of the Great Pyramid to the nearest meter.

Calculate the area of the base of the Great Pyramid.

Calculate the volume of the Great Pyramid.

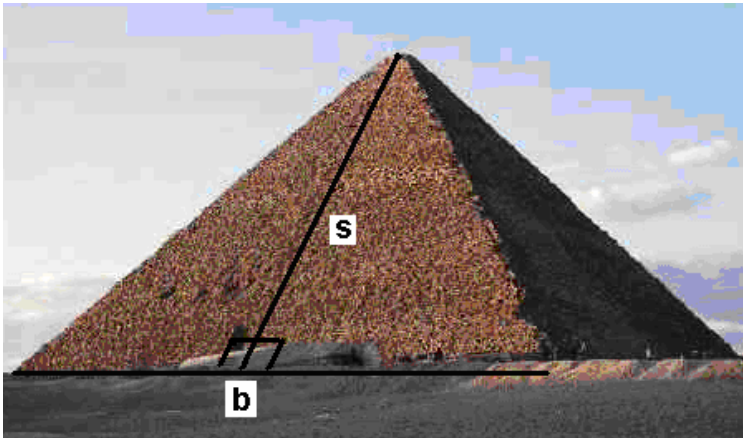

G.G.49 Investigate, justify, and apply theorems regarding chords of a circle:

- perpendicular bisectors of chords
- the relative lengths of chords as compared to their distance from the center of the circle

G.G.49a

Prove that if a radius of a circle passes through the midpoint of a chord, then it is perpendicular to that chord. Discuss your proof.

G.G.49b

Using dynamic geometry, draw a circle and its diameter. Through an arbitrary point on the diameter (not the center of the circle) construct a chord perpendicular to the diameter. Drag the point to different locations on the diameter and make a conjecture. Discuss your conjecture with a partner.

G.G.49c

Use a compass or dynamic geometry software to draw a circle with center C and radius 2 inches. Choose a length between 0.5 and 3.5 inches. On the circle draw four different chords of the chosen length. Draw and measure the angle formed by joining the endpoints of each chord to the center of the circle.

What do you observe about the angles measures found for chords of the same length?

What happens to the central angle as the length of the chord increases?

What happens to the central angle as the length of the chord decreases?

G.G.50 Investigate, justify, and apply theorems about tangent lines to a circle:

- a perpendicular to the tangent at the point of tangency
- two tangents to a circle from the same external point
- common tangents of two non-intersecting or tangent circles

G.G.50a

In the diagram below a belt touches $\frac{2}{3}$ of the circumference of each pulley. The length of the belt is 146.2 inches

What is the distance between two tangent points to the nearest tenth of an inch?

What is the distance between the centers of the pulleys, to the nearest tenth?

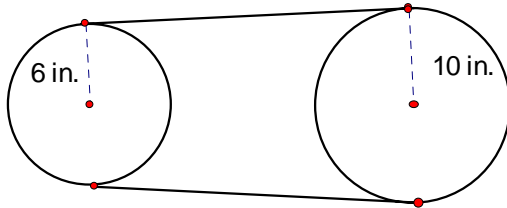

G.G.51 Investigate, justify, and apply theorems about the arcs determined by the rays of angles formed by two lines intersecting a circle when the vertex is:

- inside the circle (two chords)
- on the circle (tangent and chord)
- outside the circle (two tangents, two secants, or tangent and secant)

G.G.51a

Find the value of each variable.

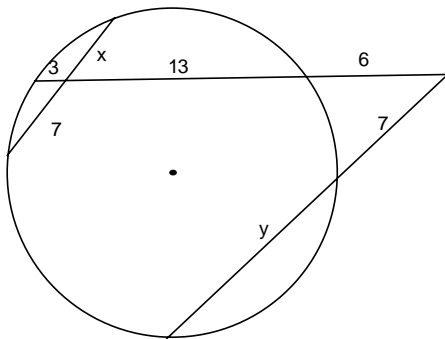

G.G.51b

Use a compass or computer software to draw a circle with center C . Draw a chord \overline{AB} .

Choose and label four points on the circle and on the same side of chord \overline{AB} .

Draw and measure the four angles formed by the endpoints of the chord and each of the four points.

What do you observe about the measures of these angles?

Measure the central angle, $\angle ACB$.

Is there any relationship between the measure of an inscribed angle formed using the endpoints of the chord and another point on the circle and the central angle formed using the endpoints of the chord?

Suppose the four points chosen on the circle were on the other side of the chord.

How are the inscribed angles formed using these points and the endpoints of the chord related to the inscribed angles formed in the first question?

G.G.52 Investigate, justify, and apply theorems about arcs of a circle cut by two parallel lines

G.G.52a

In the accompanying figure, \overleftrightarrow{AB} intersects circle O at points K and R and \overleftrightarrow{CD} which is parallel to \overleftrightarrow{AB} intersects circle O at S and T . Make a conjecture regarding minor arcs \widehat{KT} and \widehat{RS} ?

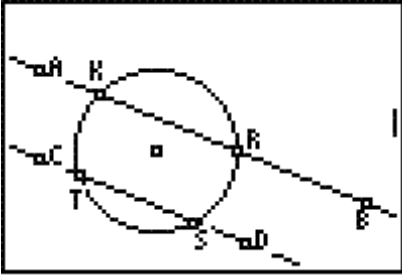

G.G.52b The accompanying figure, line m is tangent to the circle at point T . Line l is parallel to line m and intersects the circle at points R and S . Prove that $\triangle RST$ is isosceles.

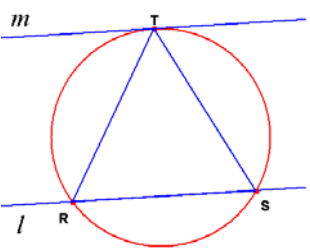

G.G.53 Investigate, justify, and apply theorems regarding segments intersected by a circle:

- along two tangents from the same external point
- along two secants from the same external point
- along a tangent and a secant from the same external point
- along two intersecting chords of a given circle

G.G.53a

Find the value of each variable.

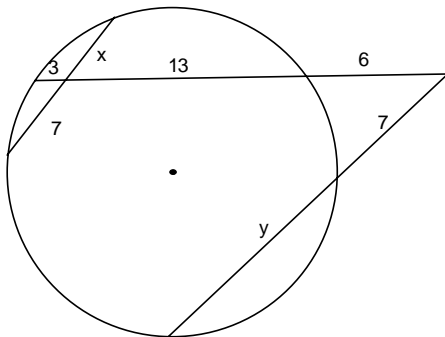

G.G.53b

The accompanying figure, \overline{AB} is tangent to the circle at point D , \overline{BC} is tangent to the circle at point E , and \overline{AC} is tangent to the circle at point F . Find the perimeter of $\triangle ABC$.

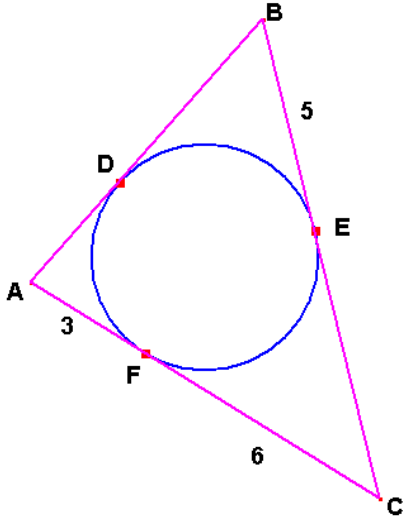

G.G.53c

Place a dot on a piece of paper. Now take four coins and place them on the piece of paper so they are tangent to each other in such a way that the dot is visible. What is true about the segments drawn from the dot to the points of tangency? Justify your answer.

Students will apply transformations and symmetry to analyze problem solving situations.

Transformational Geometry

G.G.54 Define, investigate, justify, and apply isometries in the plane (rotations, reflections, translations, glide reflections) Note: Use proper function notation.

G.G.54a

In Quadrant I draw segment \overline{AB} that is parallel to the y-axis. Let segment $\overline{A'B'}$ be the image of segment \overline{AB} under reflection over the y-axis. What type of quadrilateral is $BAA'B'$? Justify your answer.

G.G.54b

In the accompanying diagram point T is on \overline{RQ} and $\overline{PS} \perp \overline{RQ}$. If $\overline{PQ} \cong \overline{TQ}$ and $\overline{RQ} \cong \overline{QS}$, use the properties of transformations to justify that $\triangle PQR \cong \triangle TQS$.

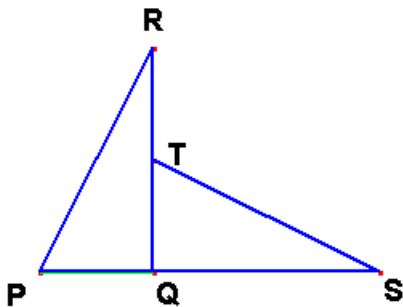

G.G.54c

In the accompanying diagram figure $\triangle XYZ$ is the image of $\triangle ABC$ under a glide reflection. Determine the line of reflection and the vector of translation that defines the glide reflection

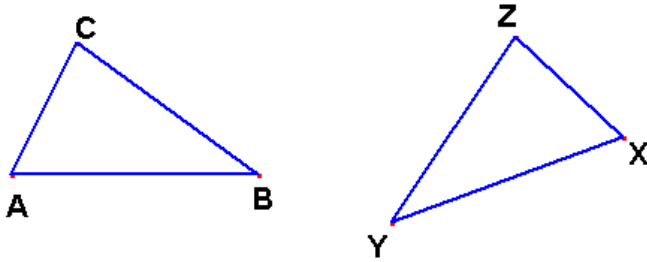

G.G.54d

The equation for a reflection over the y -axis, $R_{x=0}$, is $R_{x=0}(x, y) \rightarrow (-x, y)$. Find a pattern for reflecting a point over another vertical line such as $x = 4$. Write an equation for reflecting a point over any vertical line $x = k$.

G.G.54e

The equation for a reflection over the x -axis, $R_{y=0}$, is $R_{y=0}(x, y) \rightarrow (x, -y)$.

Find a pattern for reflecting a point over another horizontal line such as $y = 3$.

Write an equation for reflecting a point over any horizontal line $y = h$.

G.G.55 Investigate, justify, and apply the properties that remain invariant under translations, rotations, reflections, and glide reflections

G.G.55a

Jose conjectures that in the figure below $\triangle A'BC'$ is the image of $\triangle ABC$ under a reflection in some line. Explain whether Jose's conjecture is correct.

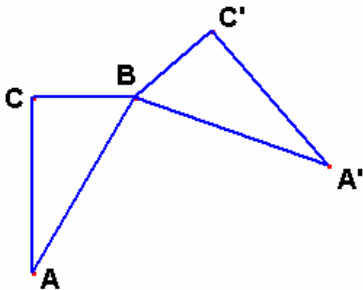

G.G.55b

A figure or property that remains unchanged under a transformation of the plane is said to be *invariant*. Which of the following properties, if any, are invariant under every isometry: area, angle congruence, collinearity, distance, orientation, parallelism. Provide a counterexample for any property that is not invariant under every isometry.

G.G.56 Identify specific isometries by observing orientation, numbers of invariant points, and/or parallelism

G.G.56a

In the figure below, $\triangle A'B'C'$ is the image of $\triangle ABC$ under an isometry. Using the properties of isometries, determine whether the isometry is a rotation, translation, reflection or a glide reflection. Explain which properties lead you to your conclusion.

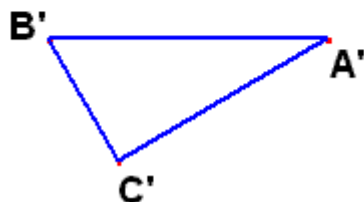
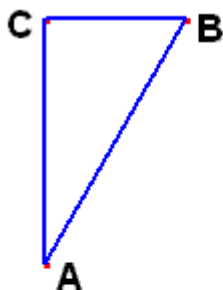

G.G.56b

In the accompanying diagram point T is on \overline{RQ} and $\overline{PS} \perp \overline{RQ}$. If $\overline{PQ} \cong \overline{TQ}$ and $\overline{RQ} \cong \overline{QS}$, use the properties of transformations to justify that $\triangle PQR \cong \triangle TQS$.

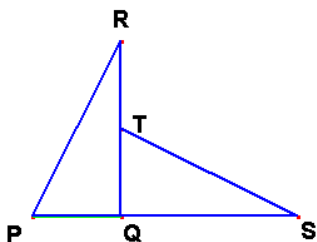

G.G.56c

In Quadrant I draw segment \overline{AB} that is parallel to the y-axis. Let segment $\overline{A'B'}$ be its reflection over the y-axis. What type of quadrilateral is $BAA'B'$? Explain.

G.G.56d

In the accompanying diagram figure $ABCD$ is a parallelogram and \overline{AC} and \overline{BD} are diagonals that intersect at point E . Identify precisely, which isometry can be used to map $\triangle AED$ onto $\triangle CEB$. Use the properties of a parallelogram to prove that $\triangle CEB$ is the image of $\triangle AED$ under that isometry.

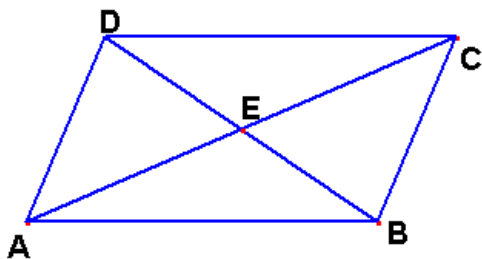

G.G.56e

Graph $\triangle ABC$ where $A(-2, -1)$, $B(1, 3)$, and $C(4, -3)$.

Show that $D(2, 1)$ is a point on \overline{BC} .

Show that \overline{AD} is perpendicular to segment \overline{BC} . How is \overline{AD} related to $\triangle ABC$?

Find the area of $\triangle ABC$.

Sketch the image of $\triangle ABC$ under a reflection over the line $y = x$.

Find the area of the image triangle.

Sketch the image of $\triangle ABC$ under a translation, $T_{-3,4}$ and find the area of the image triangle. Make a conjecture.

G.G.57 Justify geometric relationships (perpendicularity, parallelism, congruence) using transformational techniques (translations, rotations, reflections)

G.G.57a

In the accompanying diagram figure $\triangle RQ'R'$ is the image of $\triangle PQR$ under a translation through vector \overline{PR} . Prove that $\overline{Q'R'}$ is parallel to \overline{QR} .

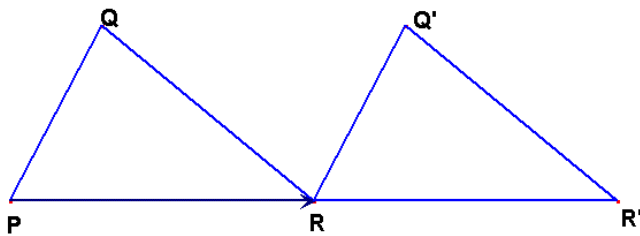

G.G.58 Define, investigate, justify, and apply similarities (dilations and the composition of dilations and isometries)

G.G.58a

A triangle has vertices $A(3,2)$, $B(4,1)$, and $C(4,3)$. Find the coordinates of the image of the triangle under a glide reflection, $G_{v,l} = T_v \circ R_l$, where $v = (0,1)$ and l is the line, $x = 0$

G.G.58b

In the accompanying figure, D is the midpoint of \overline{AC} and E is the midpoint of \overline{BC} . Use a dilation to prove that $DE = \frac{1}{2} AB$.

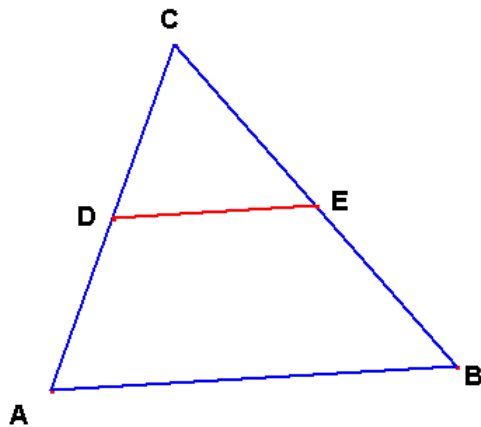

G.G.58c

Suppose that a dilation D_k centered at the origin is performed on the segment connecting the points (a, b) and (c, d) .

What are the coordinates of the image points?

Use the distance formula to show that the length of the image segment is k times the length of the pre-image segment.

G.G.59 Investigate, justify, and apply the properties that remain invariant under similarities

G.G.59a

A figure or property that remains unchanged under a transformation of the plane is said to be *invariant*. Which of the following properties, if any, are invariant under *every* similarity: area, angle congruence, collinearity, distance, orientation, parallelism. Provide a counterexample for any property that is not invariant under every similarity.

G.G.59b

In the following figure $\triangle A'B'C'$ is the image of $\triangle ABC$ under a dilation whose center is point P . Describe a procedure that could be used to find point P . Explain what property(ies) of dilations are necessary to justify your result.

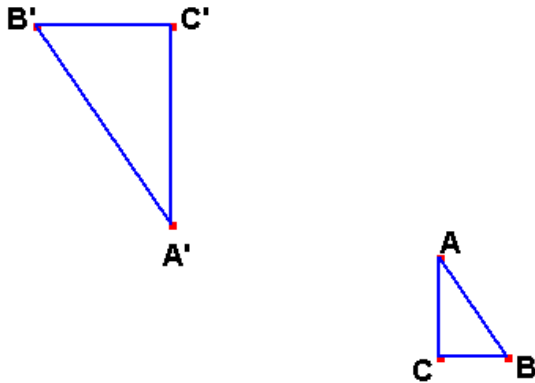

G.G.60 Identify specific similarities by observing orientation, numbers of invariant points, and/or parallelism

G.G.60a

In the accompanying figure, $\triangle ABC$ is an equilateral triangle. If $\triangle ADE$ is similar to $\triangle ABC$, describe the isometry and the dilation whose composition is the similarity that will transform $\triangle ABC$ onto $\triangle ADE$.

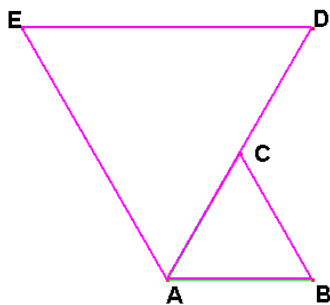

G.G.60b

Harry claims that $\triangle PMN$ is the image of $\triangle NOP$ under a reflection over \overline{PN} . How would you convince him that he is incorrect? Under what isometry would $\triangle PMN$ be the image of $\triangle NOP$?

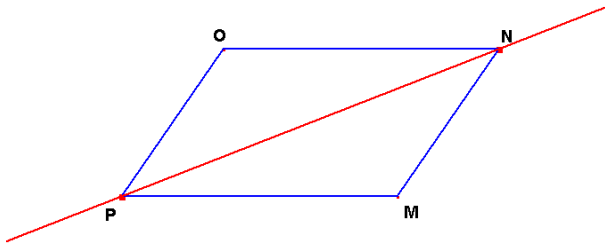

G.G.61 Investigate, justify, and apply the analytical representations for translations, rotations about the origin of 90° and 180° , reflections over the lines $x = 0$, $y = 0$, and $y = x$, and dilations centered at the origin

G.G.61a

Mary claims that in the accompanying figure, $\triangle A'B'C'$ appears to be the image of $\triangle ABC$ under a rotation of 90° about the origin O. Write the analytical equations for $R_{0,90}(x, y)$ and use them to verify Mary's conjecture.

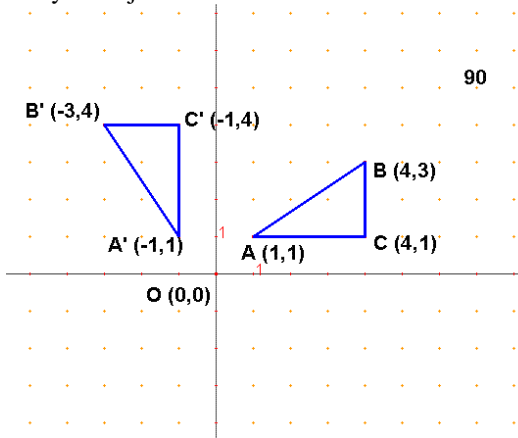

G.G.61b

Consider a line that contains the points (a, b) and (c, d) . Use these general coordinates to prove the following properties of transformations. Under a translation $T_{h,k}$, the image of a line is a line parallel to the pre-image line. Under a 180° rotation, the image of a line is a line parallel to the pre-image line. Under a dilation D_k , the image of a line is a line parallel to the pre-image line

G.G.61c

Consider each of the following compositions of transformations performed on a point (x, y) :

- a dilation and a rotation
- a dilation and a translation

Use the general coordinates to show that the order of each composition either produces the same image or different images

G.G.61d

Consider the figure below. Write using proper notation, a composition of transformations that will map triangle $\triangle ABC$ onto $\triangle A'B'C'$.

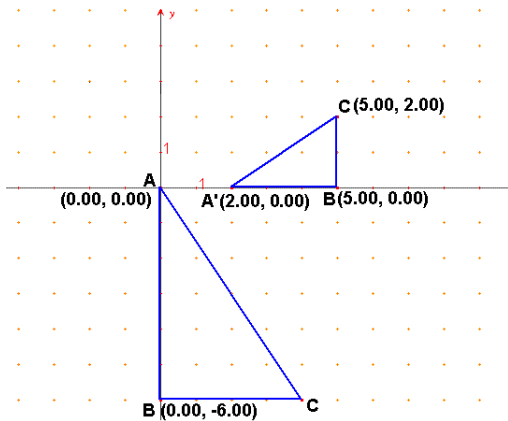

Students will apply coordinate geometry to analyze problem solving situations.

Coordinate Geometry

G.G.62 Find the slope of a perpendicular line, given the equation of a line

G.G.62a

Determine the slope of a line perpendicular to the line whose equation is $0.5x - 3y = 9$.

G.G.62b

In the accompanying figure, $A(2, 2)$, $B(9, 3)$, and $C(5, 7)$. If \overline{AD} is the altitude to side \overline{BC} of $\triangle ABC$, what is the slope of \overline{AD} ? What is the equation of \overline{AD} ?

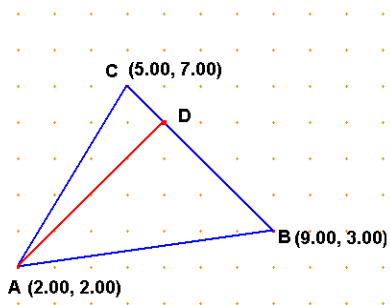

G.G.63 Determine whether two lines are parallel, perpendicular, or neither, given their equations

G.G.63a

The equations of two lines are $2x + 5y = 3$ and $5x = 2y - 7$. Determine whether these lines are parallel, perpendicular, or neither, and explain how you determined your answer.

G.G.63b

In the following figure, prove that quadrilateral $PQRS$ is a trapezoid and that \overline{TS} is an altitude.

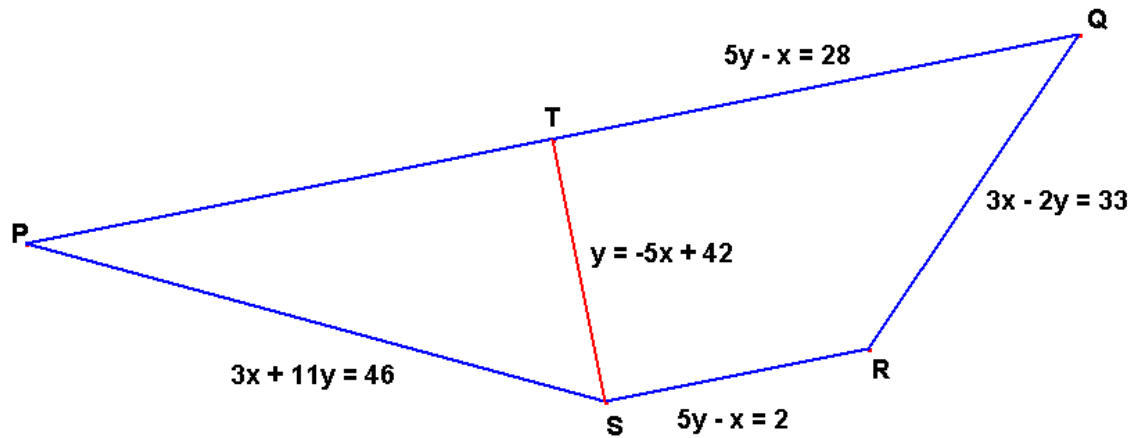

G.G.64 Find the equation of a line, given a point on the line and the equation of a line perpendicular to the given line

G.G.64a

Write the equation of the line perpendicular to $3x + 4y = 12$ and passing through the point $(-1, 3)$.

G.G.64b

In the accompanying diagram, line m is the image of line l under a rotation about point P through an angle of 90° . If the equation of line l is $2x + 3y = -5$ and the coordinates of point P are $(2, -3)$, find the equation of line m .

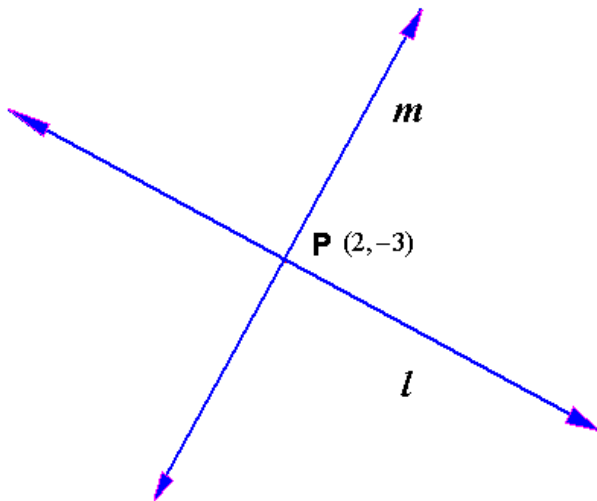

G.G.65 Find the equation of a line, given a point on the line and the equation of a line parallel to the desired line

G.G.65a

In the accompanying figure parallelogram $ABCD$ is shown with a vertex A at $(-1, 4)$. The equation of the \overline{DC} is given. Write the equation of the line passing through A and B .

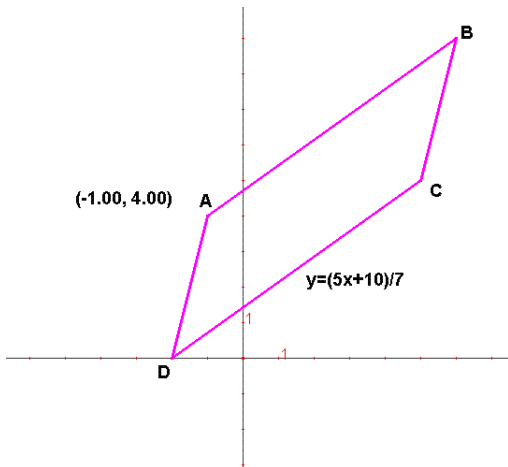

G.G.65b

In the accompanying diagram, line m is the image of line l under a translation through vector, PQ . If the equation of line l is $2x + 3y = -5$, the coordinates of point P are $(2, -3)$, and the coordinates of point Q are $(6, -2)$, find the equation of line m .

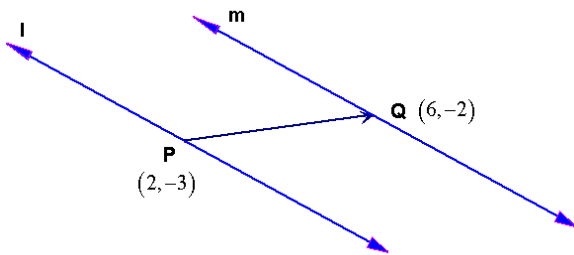

G.G.66 Find the midpoint of a line segment, given its endpoints

G.G.66a

\overline{ST} is the diameter of the circle shown in the accompanying figure. Determine the center of the circle.

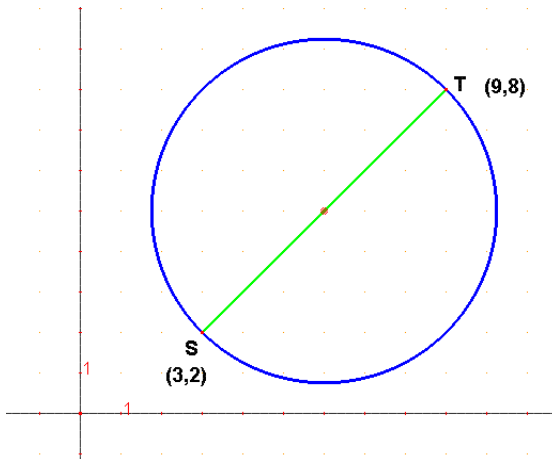

G.G.66b

In the accompanying diagram of a line, point A is the image of point B under a rotation of 180° about point M . If the coordinates of point A are $(2, -3)$, and the coordinates of point B are $(6, -1)$ what are the coordinates of point M ?

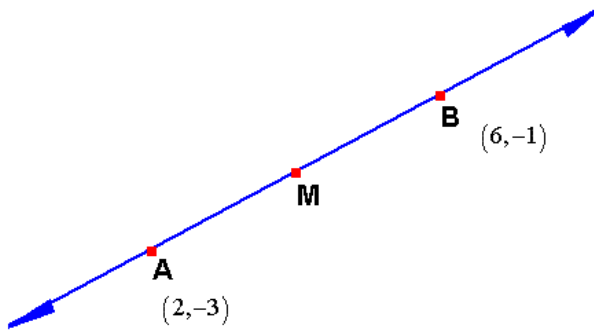

G.G.67 Find the length of a line segment, given its endpoints

G.G.67a

Determine the perimeter of a triangle whose vertices have coordinates $A(1,3)$, $B(7,9)$, and $C(11,4)$ to the nearest tenth.

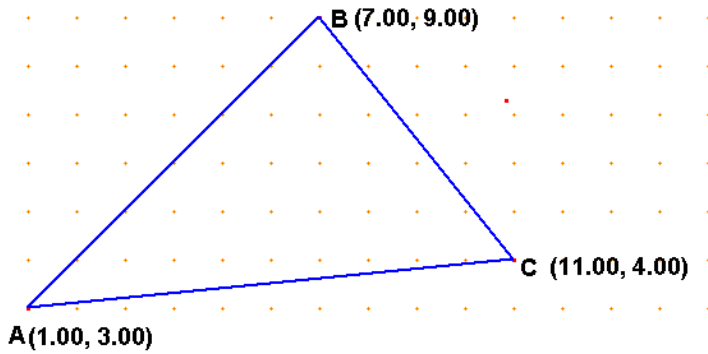

G.G.67b

In the accompanying diagram figure quadrilateral $ABCD$ is a rectangle. Prove that diagonals \overline{AC} and \overline{BD} are congruent.

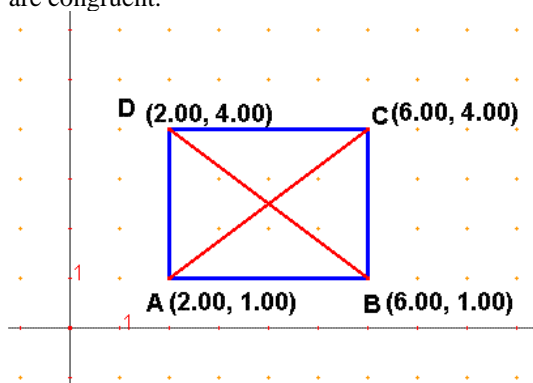

G.G.67c

One definition of a rhombus is: A parallelogram with two consecutive congruent sides. If the coordinates of point A are $(2,1)$, the coordinates of point B are $(7,4)$, the coordinates of point C are $(8,7)$, and the coordinates of point D are $(5,6)$, is quadrilateral $ABCD$ a rhombus? Defend your answer.

G.G.68 Find the equation of a line that is the perpendicular bisector of a line segment, given the endpoints of the line segment

G.G.68a

Write the equation of the locus of points equidistant between $(-5,-3)$ and $(7,5)$.

G.G.68b

If A is the image of point B under a reflection in line l , where the coordinates of point A are $(2,-3)$ and the coordinates of point B are $(6,-1)$, find the equation of line l .

G.G.69 Investigate, justify, and apply the properties of triangles and quadrilaterals in the coordinate plane, using the distance, midpoint, and slope formulas

G.G.69a

Use the information provided in the accompanying figure to prove that quadrilateral $ABCD$ is a rhombus. Prove that the diagonals of quadrilateral $ABCD$ are perpendicular bisectors of each other.

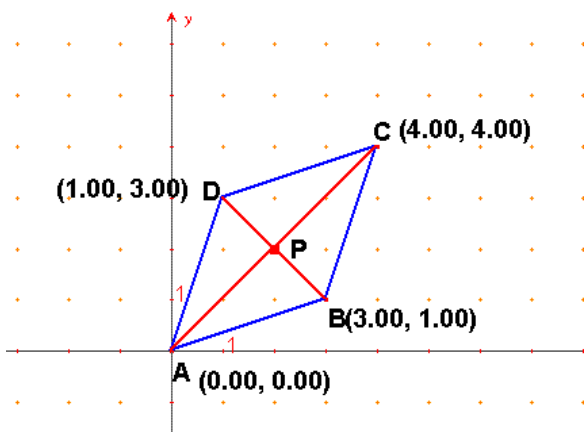

G.G.69b

Use the coordinates in the following figure to prove that $\overline{DE} \parallel \overline{AB}$ and that $DE = \frac{1}{2} AB$.

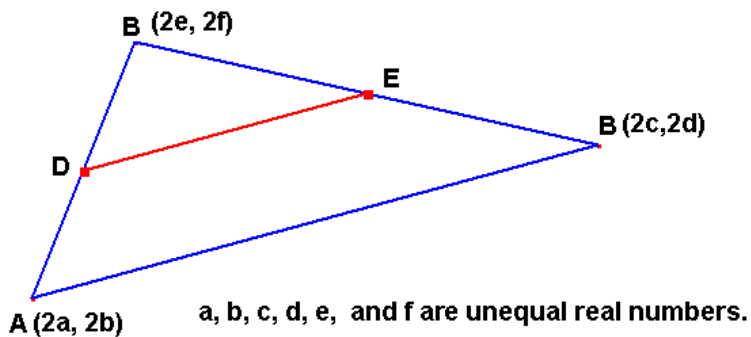

G.G.70 Solve systems of equations involving one linear equation and one quadratic equation graphically

G.G.70a

Determine where the graphs of $y = x^2 - 4x + 9$ and $y = 2x + 1$ intersect by graphing each function on the same coordinate axis system.

G.G.70b

Determine where the graphs of $x^2 + (y + 1)^2 = 25$ and $x = 3$ intersect by graphing each equation on the same coordinate axis system.

G.G.71 Write the equation of a circle, given its center and radius or given the endpoints of a diameter

G.G.71a

Describe the set of points 5 units from the point $(0,7)$ and write the equation of this set of points.

G.G.71b

The accompanying figure illustrates $\triangle ABC$ and its circumcircle O . Write the equation of circumcircle O . Find the coordinates of vertex, B .

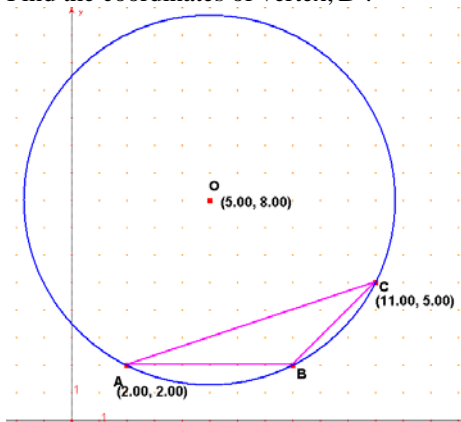

G.G.72 Write the equation of a circle, given its graph

Note: The center is an ordered pair of integers and the radius is an integer.

G.G.72a

The circle shown in the accompanying diagram has a center at $(3,4)$ and passes through the origin. Write the equation of this circle in center-radius form and in standard form.

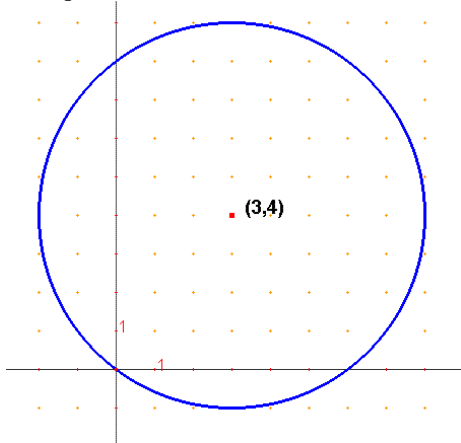

G.G.72b

In the following figure, points J , H , and K appear to be on a circle. Using the information provided, write the equation of the circle and confirm that the points actually do lie on circle.

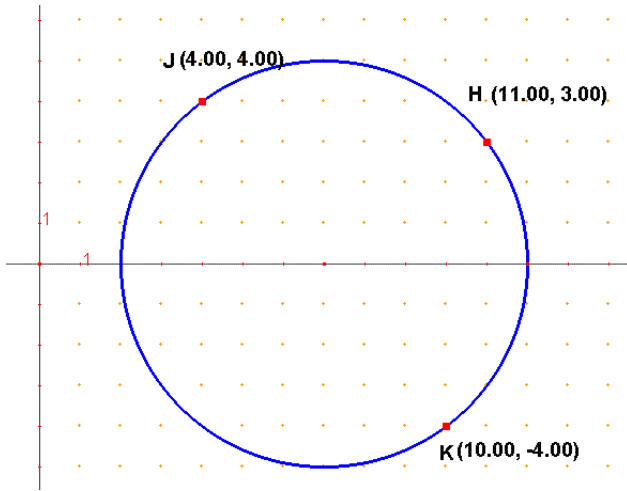

G.G.73 Find the center and radius of a circle, given the equation of the circle in center-radius form

G.G.73a

Describe the circle whose equation is given by $(y + 5)^2 + x^2 = 12$.

G.G.73b

Similar to the equation of a circle the equation of a sphere with center (h, j, k) and radius r is

$(x - h)^2 + (y - j)^2 + (z - k)^2 = r^2$. Determine the center and radius of the sphere shown if its equation is $(x + 1)^2 + (y - 3)^2 + (z - 2)^2 = 24$.

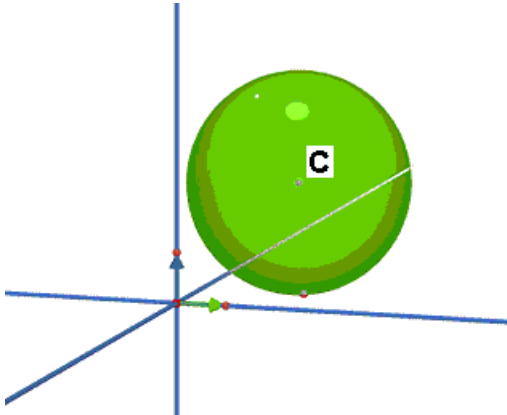

G.G.74 Graph circles of the form $(x - h)^2 + (j - k)^2 = r^2$

G.G.74a

Sketch the graph of the circle whose equation is $(x - 5)^2 + (y + 2)^2 = 25$. What is the relationship between this circle and the y-axis?

G.G.74b

Cell phone towers cover a range defined by a circle. The map below has been coordinatized with the cities of Elmira having coordinates $(0,0)$, Jamestown $(-7.5,0)$ and Schenectady $(9,3)$. The equation

$x^2 + y^2 = 16$ models the position and range of the tower located in Elmira. Towers are to be located in Jamestown and Schenectady. The tower in Jamestown is modeled by the equation

$(x + 7.5)^2 + y^2 = 12.25$ and $(x - 9)^2 + (y - 3)^2 = 25$ models the position and range of the tower centered in Schenectady. On the accompanying grid, graph the circles showing the coverage area for the two additional towers.

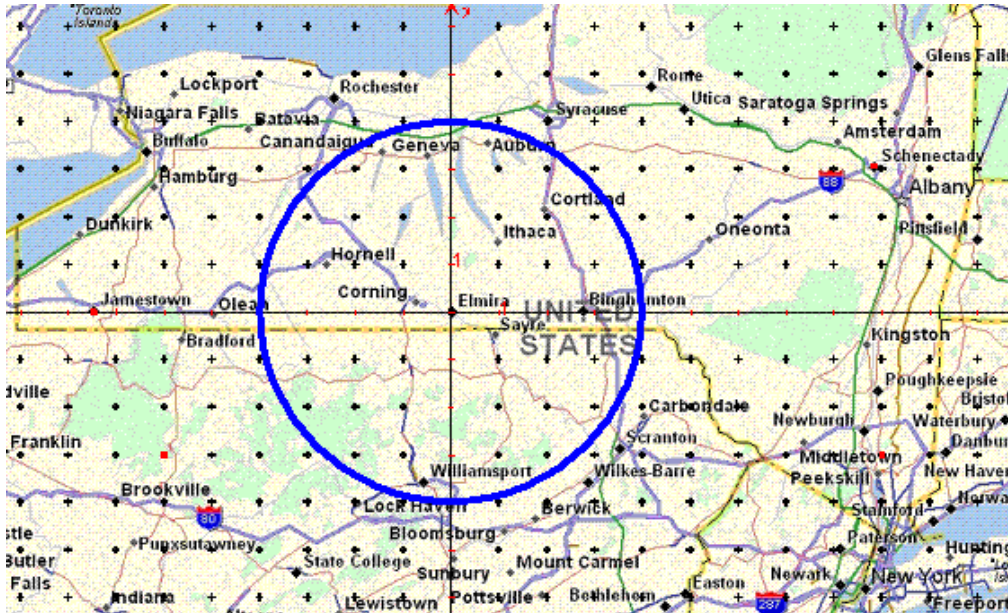

[Back to top](#)